

HIGH-POWER RMS-PLUS Assembly and Operation Instructions

READ THIS BEFORE YOU BEGIN:

• Study the illustrations and sequence of assembly. **THE SEQUENCE OF ASSEMBLY IS EXTREMELY IMPORTANT. READ ALL INSTRUCTIONS BEFORE USE. USE RMS™ MOTORS AND RELOAD KITS ONLY IN ACCORDANCE WITH ALL INSTRUCTIONS.** Review the parts list and become familiar with all parts before assembly. **IF ANY PARTS ARE MISSING OR DAMAGED, CONTACT RCS AT 1-435-865-7100 OR EMAIL AT warranty@aerotech-rocketry.com.**

• **DO NOT USE ANY PARTS OF THE RMS™ SYSTEM THAT ARE DAMAGED IN ANY WAY.** If in doubt, contact RCS at the number above for assistance.

• **DO NOT MODIFY THE MOTOR IN ANY WAY.** Modification of the motor or the reload kit parts could result in motor failure, lead to the destruction of both your rocket and motor and may cause personal injury, death and/or property damage. Modification of the motor or reload kit in any way will invalidate your motor warranty.

• **USE ONLY AEROTECH/RCS RMS™ RELOAD KITS AND MOTOR PARTS TO REFURBISH YOUR RMS™ MOTOR.** The AeroTech/RCS reload kits have been designed specifically for use in your particular AeroTech/RCS RMS™ motor. Use of imitation components may destroy your motor, rocket and payload and will invalidate your motor warranty. Only use AeroTech/RCS RMS™ reload kits intended for your specific AeroTech/RCS RMS™ motor. **DO NOT INTERCHANGE PARTS!** Do not use AeroTech/RCS RMS™ reload kits or motor components for any other purpose than to refurbish an AeroTech/RCS RMS™ motor.

• **DO NOT REUSE ANY OF THE DISPOSABLE PARTS OF THE RMS™ RELOAD KIT.** This includes the liner, nozzle and o-rings. These components have been designed for one use only and must be discarded after firing. Reuse can result in motor failure during subsequent operation and will invalidate your motor warranty.

• Motors are hot after firing. Although the RMS™ operates at a lower temperature than most disposable motors, the higher thermal conductivity of the aluminum motor parts may make it seem otherwise. If necessary to handle a motor before it has cooled down, use a rag or similar article.

• Read and follow the safety code of the Tripoli Rocketry Association (TRA) and comply with all federal, state and local laws in all activities involving high power rockets.

DO NOT OPEN RELOAD KIT UNTIL READY TO USE.

PARTS:

RMS™ HARDWARE

29mm enlarged aft closure	1
29/360 case	1
29mm std. or plugged forward closure	1
29mm forward seal ring	1

RELOAD KIT

Nozzle (black plastic part)	1
Liner (1" O.D. black plastic tube)	1
Propellant grains	6
Aft o-ring (1/16" thick X 1" O.D.)	1
Forward o-ring (3/32" thick X 1" O.D.)	1
Forward seal ring o-ring (1/16" thick X 7/8" O.D.)	1
Delay o-ring (3/32" thick X 13/16" O.D.)	1
RMS-Plus™ delay element (short solid part)	1
Delay insulator (13/16" O.D. tube)	1
Aft insulator (1" O.D. fiber washer)	1
Aft delay spacer (short paper ring)	1
Forward delay spacer (13/16" O.D. neoprene washer)	1
Ejection charge cap (adhesive paper disk)	1
FirstFire™ igniter	1
Ejection charge container (red plastic cap)	1
Nozzle cap (13/16" O.D. red plastic cap)	1

ITEMS NEEDED FOR USE:

- Synco™ Super Lube™ or other grease
- Hobby knife or scissors
- Wet wipes or damp paper towels

SAVE THE RELOAD KIT PLASTIC BAG FOR THE USED RELOAD PARTS. DISPOSE OF BAG AND PARTS PROPERLY.

Chapter 1. Forward Closure Assembly

1-1. Apply a light coat of Synco™ Super Lube™ or other grease to all threads and all 4 o-rings. This will facilitate assembly and prevents the threads from seizing.

1-2. **Fig.-1:** Chamfer both inner edges of the delay insulator with your fingernail. Assemble the RMS-Plus delay element, delay insulator, aft delay spacer and delay o-ring as shown. **NOTE:** It is **not** necessary to tape the delay element or delay insulator, the hot gas seal is provided by the delay o-ring alone.

1-3. **Fig.-2:** Insert the forward delay spacer (13/16" O.D. neoprene washer) into the delay cavity until it is seated against the forward end of the cavity. Apply a **light film** of grease to the inner circumference of the delay cavity (but **not** the forward end of the cavity).

1-4. **Fig.-3:** Insert the delay charge assembly shown in Fig.-1 into the delay cavity, o-ring end first, until it is seated against the forward delay spacer. **NOTE:** When using a **plugged** forward closure **ONLY**, fill the opening in the forward delay spacer with grease prior to installing the delay charge assembly.

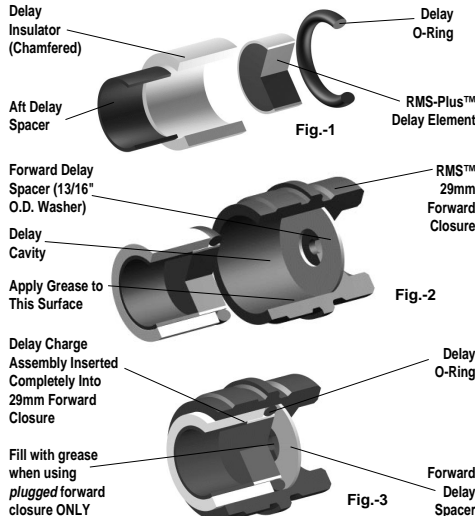

Chapter 2. Case Assembly

2-1. **Fig.-4:** Place the greased forward seal ring (1/16" thick X 7/8" O.D.) o-ring into the groove in the forward seal ring.

2-2. **Fig.-5:** Using a hobby knife or similar tool, gently remove the burr (rough, raised edge) from both inside ends of the liner tube. Insert the smaller (o-ring) end of the seal ring into one end of the liner tube until the seal ring flange is seated against the end of the liner.

2-3. **Fig.-6:** Install the six (6) propellant grains into the liner. **NOTE:** Four grains are shown in all illustrations for clarity. RMS-29/360 motors use six (6) grains.

2-4. **Fig.-7:** Push the liner assembly into the motor case until it is approximately equally recessed from both ends of the case. **NOTE:** A light coat of grease on the outside surface of the liner will facilitate installation and casing cleanup after motor firing.

2-5. **Fig.-8:** Place the greased forward (**THICKER** 3/32" thick X 1" O.D.) o-ring into the forward (bulkhead) end of the case until it is seated against the forward seal ring.

2-6. **Fig.-9:** With the motor case held in a horizontal position, thread the previously assembled forward closure assembly into the forward end of the motor case by hand until it is seated against the case.

2-7. **Fig.-10:** Place the aft insulator (1" O.D. fiber washer) into the aft (nozzle) end of the motor case, seated against the liner assembly.

2-8. **Fig.-11:** Insert the larger end of the nozzle into the aft end of the case and against the aft insulator.

2-9. **Fig.-12:** Place the greased aft (**THINNER** 1/16" thick X 1" O.D.) o-ring into the aft end of the motor case, seated in the groove between the nozzle and the case.

2-10. **Fig.-13:** Thread the enlarged aft (gold) closure into the aft end of the motor case by hand until it is seated against the case. **NOTE:** There will be some resistance to threading in the closure during the last 1/32" to 1/16" of travel. It is normal if the grains rattle slightly in the liner after tightening.

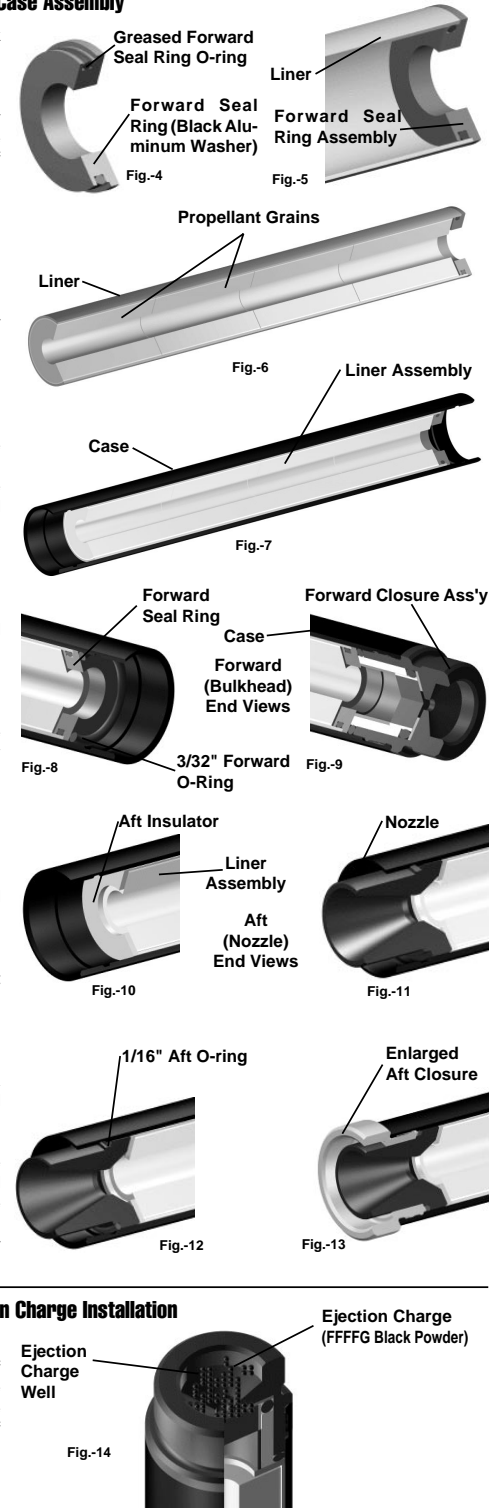

Chapter 3. Ejection Charge Installation

3-1. **Fig.-14:** Thoroughly clean the outside of the motor of any grease or other residue. Open the ejection charge container (5/8" O.D. red plastic cap) and dispense enough ejection charge into the ejection charge well of the forward closure to fill the well approximately 3/4 full. **NOTE:** For 4" and larger diameter rockets, fill the well **completely**.

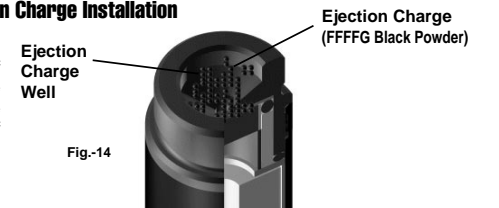

Chapter 3. Ejection Charge Installation (Cont'd)

- 3-2. Fig.-15: Apply the ejection charge cap (adhesive paper disk) to the center of the end of the forward closure. With the motor held in a **NOZZLE DOWN** position, gently shake the motor to settle the ejection charge into the cavity above the delay element.

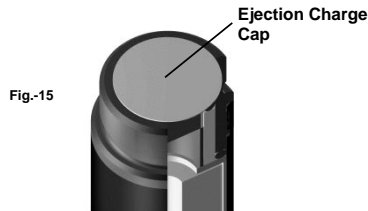

Chapter 4. Preparation For Flight

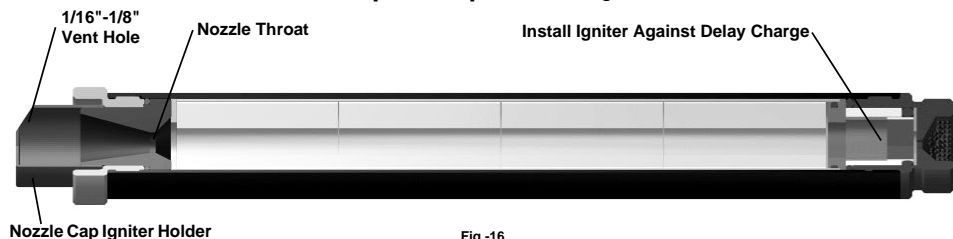

- 4-1. Fig.-16: Using a hobby knife, cut a corner off the red nozzle cap (13/16" O.D. red plastic cap) to create a small (1/16"-1/8") vent hole. Set the nozzle cap aside.
- 4-2. Fig.-16: Insert the coated end of the FirstFire™ or other igniter through the nozzle throat until it stops against the delay element or forward seal ring.
- 4-3. Push the vented nozzle cap igniter holder over the igniter lead(s) and nozzle until it stops.
- 4-4. Install the motor into the rocket's motor mount tube. Ensure that the motor is securely retained in the rocket by using positive mechanical means to prevent it from being ejected at the time of ejection charge firing.
- 4-5. Prepare the rocket's recovery system and then launch the rocket in accordance with the Tripoli Rocketry Association (TRA) Safety Code and National Fire Protection Association (NFPA) Code 1127.

- 5-4. Apply a light coat of grease to all threads and the inside of the motor case. Reassemble metal parts and store motor in a dry place.

Chapter 5. Post-Recovery Cleanup

NOTE: Perform motor clean-up as soon as possible after motor firing. Propellant and delay residues become difficult to remove after 24 hours and can lead to corrosion of the metal parts. Place the spent motor components in the reload kit plastic bag and dispose of properly.

- 5-1. After the motor has cooled down, remove the forward and aft closures.
- 5-2. Remove the delay insulator, delay o-ring and forward delay spacer from the forward closure and discard. Remove and discard the nozzle and the forward and aft o-rings. Using wet wipes or damp paper towels, remove all delay and propellant residue from the closures. **WARNING: FAILURE TO COMPLETELY REMOVE DELAY RESIDUE FROM THE INSIDE OF THE FORWARD CLOSURE CAN LEAD TO GAS LEAKAGE ON A SUBSEQUENT FLIGHT AND DAMAGE TO YOUR RMS MOTOR FORWARD CLOSURE AND ROCKET VEHICLE.**
- 5-3. Remove the liner from the casing by pushing on either end. Remove the forward seal ring from the liner. Discard the liner and forward seal ring o-ring **ONLY**. Using wet wipes or damp paper towels, wipe the inside of the casing and the forward seal ring to remove all propellant residue. **DO NOT** discard the forward seal ring!

AeroTech Division
RCS Rocket Motor Components, Inc.
Cedar City, UT 84720
www.aerotech-rocketry.com

P/N 20053 Rev. 4/10/06
Made in U.S.A.

©2006 RCS Rocket Motor Components, Inc., All rights reserved

Division of RCS Rocket Motor Components, Inc.

HIGH-POWER RMS™

Reloadable Motor System

With **RMS PLUS™** Advanced Delay Sealing System

**DO NOT OPEN
RELOAD KIT
UNTIL READY
TO USE**

RMS™ 29/360 WHITE LIGHTNING™

Typical Time-Thrust Curve:
Certified By the Tripoli Rocketry Association

THIS PACKAGE CONTAINS ONE RMS-PLUS™ RELOAD KIT:

1200W-M (29/360)

NOTE: MEDIUM DELAY CHARGE COMPONENTS INCLUDED. For other delay times, use one of the appropriate AeroTech Reload Delay Kits (RDK's) for the delay time desired. Please refer to the RDK cross-reference list on back of the reload kit header card for proper RDK selection.

R = Redline™ Short = approx. 6 sec, Medium = approx. 10 sec., Long = approx. 14 sec.
NOTE: The reload kit shown above is ONLY for use in AeroTech RMS™-29/360 high-power motors.

RMS-29/360 WHITE LIGHTNING RELOAD KIT DATA

Hardware Designation	Performance Designation	Total Impulse (Maximum)	Propellant Weight	Loaded Motor Weight
RMS™-29/360	1200W	330 N-sec	175 g (0.390 lb)	364 g (0.802 lb)

Note: Total impulse shown is optimum.

RMS-29/360 HARDWARE DATA

Hardware Designation	Motor Diameter	Motor Length	Hardware Weight	Reload Used
RMS™-29/360	1.125" (29mm)	13.10"	138 g (0.304 lb)	1200W

NOTE: Motor lengths are measured from end of aft closure to end of forward closure.

NOTE: SALE TO PERSONS UNDER 18 YEARS OF AGE PROHIBITED BY FEDERAL LAW. WARNING-FLAMMABLE: Read Instructions Before Use. KEEP OUT OF REACH OF CHILDREN. FOR USE ONLY BY CERTIFIED HIGH-POWER USERS 18 YEARS OF AGE OR OLDER. DO NOT SMOKE when loading these motors or use in the vicinity of open flames.