

HIGH-POWER RMS-PLUS™ Assembly and Operation Instructions

READ THIS BEFORE YOU BEGIN:

• Study the illustrations and sequence of assembly. **THE SEQUENCE OF ASSEMBLY IS EXTREMELY IMPORTANT. READ ALL INSTRUCTIONS BEFORE USE. USE RMS™ MOTORS AND RELOAD KITS ONLY IN ACCORDANCE WITH ALL INSTRUCTIONS.** Review the parts list and become familiar with all parts before assembly. **IF ANY PARTS ARE MISSING OR DAMAGED, CONTACT RCS AT 1-435-865-7100.**

• **DO NOT USE ANY PARTS OF THE RMS™ SYSTEM THAT ARE DAMAGED IN ANY WAY.** If in doubt, contact RCS at the number above for assistance.

• **DO NOT MODIFY THE MOTOR IN ANY WAY.** Modification of the motor or the reload kit parts could result in motor failure, lead to the destruction of both your rocket and motor and may cause personal injury, death and/or property damage. Modification of the motor or reload kit in any way will invalidate your motor warranty.

• **USE ONLY AEROTECH/RCS RMS™ RELOAD KITS AND MOTOR PARTS TO REFURBISH YOUR RMS™ MOTOR.** The AeroTech/RCS reload kits have been designed specifically for use in your particular AeroTech/RCS RMS™ motor. Use of imitation components may destroy your motor, rocket and payload and will invalidate your motor warranty. Only use AeroTech/RCS RMS™ reload kits intended for your specific AeroTech/RCS RMS™ motor. **DO NOT INTERCHANGE PARTS!** Do not use AeroTech/RCS RMS™ reload kits or motor components for any other purpose than to refurbish an AeroTech/RCS RMS™ motor.

• **DO NOT REUSE ANY OF THE DISPOSABLE PARTS OF THE RMS™ RELOAD KIT.** This includes the liner, nozzle and o-rings. These components have been designed for one use only and must be discarded after firing. Reuse can result in motor failure during subsequent operation and will invalidate your motor warranty.

• Motors are hot after firing. Although the RMS™ operates at a lower temperature than most disposable motors, the higher thermal conductivity of the aluminum motor parts may make it seem otherwise. If necessary to handle a motor before it has cooled down, use a rag or similar article.

• Read and follow the safety code of the Tripoli Rocketry Association (TRA) and comply with all federal, state and local laws in all activities involving high power rockets.

DO NOT OPEN RELOAD KIT UNTIL READY TO USE.

PARTS:

RMS™ HARDWARE

38mm enlarged aft closure	1
38/480 case	1
38mm std. or plugged forward closure	1
38mm forward seal ring	1

RELOAD KIT

Nozzle (black plastic part)	1
Liner (1-3/8" O.D. black plastic tube)	1
Propellant grains	3
Aft o-ring (3/16" thick X 1-3/8" O.D.)	1
Forward o-ring (1/8" thick X 1-3/8" O.D.)	1
Fwd seal ring o-ring (1/16" thick X 1-5/16" O.D.)	1
Aft insulator (1-3/8" O.D. fiber washer)	1
FirstFire™ igniter	1
Nozzle cap (13/16" O.D. red plastic cap)	1
RMS-Plus™ delay element (short solid part)	1
Delay insulator (13/16" O.D. tube)	1
Delay o-ring (3/32" thick X 13/16" O.D.)	1
Aft delay spacer (short colored paper ring)	1
Forward delay spacer (13/16" O.D. neoprene washer)	1

ITEMS NEEDED FOR USE:

- Synco™ Super Lube™ or other grease
- Hobby knife
- Wet wipes or damp paper towels

SAVE THE RELOAD KIT PLASTIC BAG FOR THE USED RELOAD PARTS. DISPOSE OF BAG AND PARTS PROPERLY.

Chapter 2. Case Assembly

2-1. **Fig.-4:** Place the greased forward seal ring (1/16" thick X 1-5/16" O.D.) o-ring into the groove in the forward seal ring.



2-2. **Fig.-5:** Using a hobby knife or similar tool, gently remove the burr (rough, raised edge) from both inside ends of the liner tube. Insert the smaller (o-ring) end of the seal ring into one end of the liner tube until the seal ring flange is seated against the end of the liner.

2-3. **Fig.-6:** Install the propellant grains into the liner. **NOTE:** If the grains are a tight fit in the liner, the "glassine" outer paper layer may be peeled from the grain outer surface.

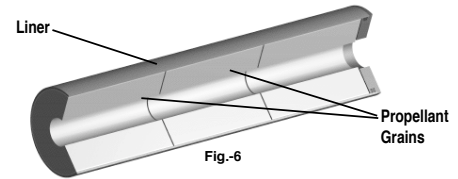

2-4. **Fig.-7:** Push the liner assembly into the motor case until it is equally recessed from both ends of the case. **NOTE:** A light coat of grease on the outside surface of the liner will facilitate installation and casing cleanup after motor firing.

2-5. **Fig.-8:** Place the greased forward (1/8" thick X 1-3/8" O.D.) o-ring into the forward (bulkhead) end of the case until it is seated against the forward seal ring.

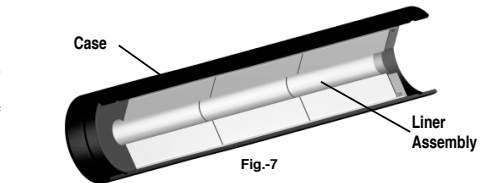

2-6. **Fig.-9:** With the motor case held in a horizontal position, thread the previously assembled forward closure assembly into the forward end of the motor case by hand until it is seated against the case.

2-7. **Fig.-10:** Place the aft insulator (1-3/8" O.D. fiber washer) into the aft (nozzle) end of the motor case, seated against the liner assembly.

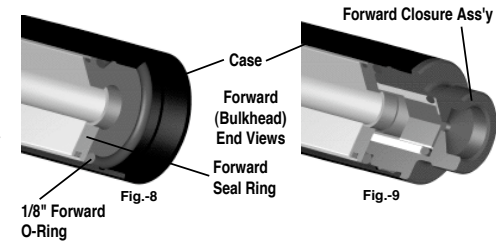

2-8. **Fig.-11:** Place the greased aft (3/16" thick X 1-3/8" O.D.) o-ring into the aft end of the motor case, seated against the aft insulator.

2-9. **Fig.-12:** Push the larger end of the nozzle into the aft o-ring and against the aft insulator. The nozzle will be a snug fit in the o-ring.

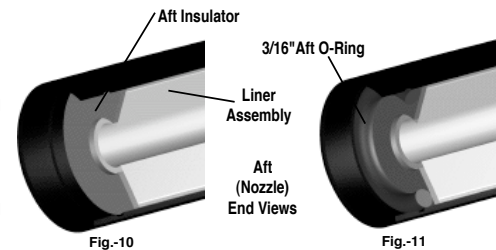

2-10. **Fig.-13:** Thread the aft closure into the aft end of the motor case by hand until it is seated against the case. **NOTES:** There will be some resistance to threading in the closure during the last 1/32" to 1/16" of travel. It is normal if the grains rattle slightly inside the liner after tightening.

Chapter 1. Forward Closure Assembly

1-1. Apply a light coat of Synco™ Super Lube™ or other grease to all threads and all 4 o-rings. This will facilitate assembly and prevents the threads from seizing.

1-2. **Fig.-1:** Chamfer both inner edges of the delay insulator with your fingernail. Assemble the RMS-Plus delay element, delay insulator, aft delay spacer and delay o-ring as shown. **NOTE:** It is **not** necessary to tape the delay element or delay insulator, the hot gas seal is provided by the delay o-ring alone.

1-3. **Fig.-2:** Insert the forward delay spacer (13/16" O.D. neoprene washer) into the delay cavity until it is seated against the forward end of the cavity. Apply a **light film** of grease to the inner circumference of the delay cavity (but **not** the forward end of the cavity).

1-4. **Fig.-3:** Insert the delay charge assembly shown in Fig.-1 into the delay cavity, o-ring end first, until it is seated against the forward delay spacer. **NOTE:** When using a **plugged** forward closure **ONLY**, fill the opening in the forward delay spacer with grease prior to installing the delay charge assembly.

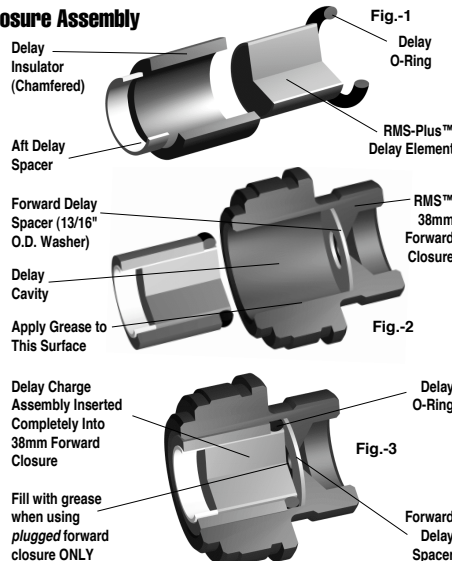

Chapter 3. Preparation For Flight

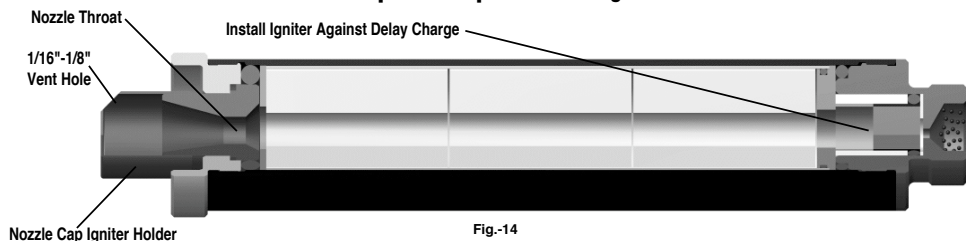

Fig.-14

- 3-1. **Fig.-14:** Using a hobby knife, cut a corner off the red nozzle cap (13/16" O.D. red plastic cap) to create a small (1/16"-1/8") vent hole. Set the nozzle cap aside.
- 3-2. **Fig.-16:** Insert the coated end of the FirstFire™ or other igniter through the nozzle throat until it stops against the delay element or forward seal ring.
- 3-3. Push the vented nozzle cap igniter holder over the igniter lead(s) and nozzle until it stops.
- 3-4. Install the motor into the rocket's motor mount tube. Ensure that the motor is securely retained in the rocket by using positive mechanical means to prevent it from being ejected at the time of ejection charge firing.
- 3-5. Prepare the rocket's recovery system and then launch the rocket in accordance with the Tripoli Rocketry Association (TRA) Safety Code and National Fire Protection Association (NFPA) Code 1127.

Chapter 4. Post-Recovery Cleanup

NOTE: Perform motor clean-up as soon as possible after motor firing. Propellant and delay residues become difficult to remove after 24 hours and can lead to corrosion of the metal parts. Place the spent motor components in the reload kit plastic bag and dispose of properly.

- 4-1. After the motor has cooled down, remove the forward and aft closures.
- 4-2. Remove the delay insulator, delay o-ring and forward delay spacer from the forward closure and discard. Remove and discard the nozzle and the forward and aft o-rings. Using wet wipes or damp paper towels, remove all delay and propellant residue from the closures. **WARNING: FAILURE TO COMPLETELY REMOVE DELAY RESIDUE FROM THE INSIDE OF THE FORWARD CLOSURE CAN LEAD TO GAS LEAKAGE ON A SUBSEQUENT FLIGHT AND DAMAGE TO YOUR RMS MOTOR FORWARD CLOSURE AND ROCKET VEHICLE.**
- 4-3. Remove the liner from the casing by pushing on either end. Remove the forward seal ring from the liner. Discard the liner and forward seal ring o-ring **ONLY**. Using wet wipes or damp paper towels, wipe the inside of the casing and the forward seal ring to remove all propellant residue. **DO NOT discard the forward seal ring!**
- 5-4. Apply a light coat of grease to all threads and the inside of the motor case. Reassemble metal parts and store motor in a dry place.

AeroTech Division
RCS Rocket Motor Components, Inc.
Cedar City, UT 84720
www.aerotech-rocketry.com

Chapter 5. First Aid

For a minor burn, apply a burn ointment. For a severe burn, immerse the burned area in ice water at once and see a physician as quickly as possible. In the unlikely event of oral ingestion of the propellant, induce vomiting and see a physician as quickly as possible. The AeroTech/RCS composite propellant consists primarily of ammonium perchlorate and a rubber-like plastic elastomer.

Chapter 6. Disposal

Damaged or defective reload kits should be returned to RCS.

Chapter 7. Fire Safety

Tests show that the pyrotechnic components of RMS™ reload kits will not explode in fires and normally will not ignite unless subjected to direct flame and then will burn slowly. Use water to fight any fires in which AeroTech/RCS RMS™ reload kit pyrotechnic components may become involved: Direct the water at the AeroTech/RCS RMS™ reload kit pyrotechnic components to keep them below their 550 deg. F autoignition temperature. Foam and carbon dioxide fire extinguishers will NOT extinguish burning propellants of the type used in RMS™ reload kit pyrotechnic components. Keep reload kit pyrotechnic components away from flames, sources of heat and flammable materials.

Disclaimer and Warranty

NOTICE: As we cannot control the storage and use of our products, once sold we cannot assume any responsibility for product storage, transportation or usage. RCS shall not be held responsible for any personal injury or property damage resulting from the handling, storage or use of our product. The buyer assumes all risks and liabilities therefrom and accepts and uses AeroTech/RCS products on these conditions. No warranty either expressed or implied is made regarding AeroTech/RCS products, except for replacement or repair, at RCS's option, of those products which are proven to be defective in manufacture within one year from the date of original purchase. For repair or replacement under this warranty, please contact RCS. Proof of purchase will be required. Note: Your state may provide additional rights not covered by this warranty.

P/N 20069-1 Rev. 4/3/07
Made in U.S.A.

©2007 RCS Rocket Motor Components, Inc., All rights reserved

Division of RCS Rocket Motor Components, Inc.

HIGH-POWER RMS™

Reloadable Motor System™

With **RMS+™** Advanced Delay Sealing System

RMS™ 38/480 WARP-9™

This Package Contains One RMS-Plus™ Reload Kit:

I1299N-P (38/480)

NOTE: Warp-9 reload kits do not include an ejection charge. Warp-9 motors must be used in conjunction with a timer, altimeter or radio-actuated recovery system.

N =Warp-9™
This reload kit is **ONLY** for use in AeroTech, Dr. Rocket™ or Rouse-Tech™ RMS™ 38/480 high-power motors.

DO NOT OPEN RELOAD KIT UNTIL READY TO USE

Typical Time-Thrust Curve:

Certified by the Tripoli Rocketry Association (TRA).

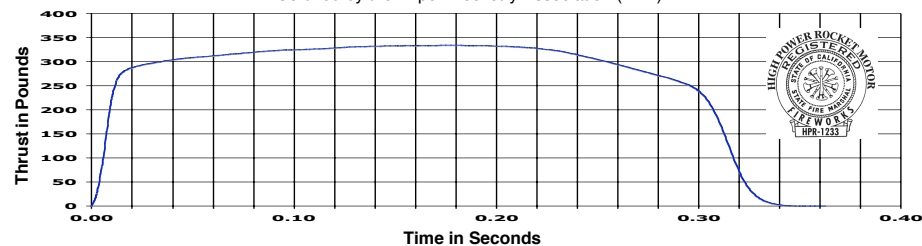

I1299N RELOAD KIT DATA

Hardware Designation	Performance Designation	Total Impulse (Maximum)	Propellant Weight	Loaded Motor Weight
RMS™-38/480	<i>I1299N-P</i>	430 N-sec	192.1 g (0.424 lb)	422 g (0.930 lb)

Note: Total impulse shown is optimum.

RMS™-38/480 HARDWARE DATA

Hardware Designation	Motor Diameter	Motor Length	Hardware Weight	Reload Used
<i>RMS™-38/480</i>	1.500" (38mm)	9.82"	168.5 g (0.371 lb)	I1299N

NOTE: Total impulse shown is optimum. Motor lengths are measured from end of aft closure to end of forward closure. I1299N reloads require enlarged 38mm aft closure for use; AeroTech part number 38AC2

NOTE: SALE OF PROPELLANT RELOAD KITS TO PERSONS UNDER 21 YEARS OF AGE PROHIBITED BY FEDERAL LAW. WARNING-FLAMMABLE: Read Instructions Before Use. KEEP OUT OF REACH OF CHILDREN. FOR USE ONLY BY CERTIFIED HIGH-POWER USERS 21 YEARS OF AGE OR OLDER. DO NOT SMOKE when loading these motors or use in the vicinity of open flames.