

HIGH-POWER RMS-PLUS™ Assembly and Operation Instructions

READ THIS BEFORE YOU BEGIN:

• Study the illustrations and sequence of assembly. **THE SEQUENCE OF ASSEMBLY IS EXTREMELY IMPORTANT. READ ALL INSTRUCTIONS BEFORE USE. USE RMS™ MOTORS AND RELOAD KITS ONLY IN ACCORDANCE WITH ALL INSTRUCTIONS.** Review the parts list and become familiar with all parts before assembly. **IF ANY PARTS ARE MISSING OR DAMAGED, CONTACT RCS AT 1-435-865-7100 OR EMAIL AT warranty@aerotech-rocketry.com.**

• **DO NOT USE ANY PARTS OF THE RMS™ SYSTEM THAT ARE DAMAGED IN ANY WAY.** If in doubt, contact RCS at the number above for assistance.

• **DO NOT MODIFY THE MOTOR IN ANY WAY.** Modification of the motor or the reload kit parts could result in motor failure, lead to the destruction of both your rocket and motor and may cause personal injury, death and/or property damage. Modification of the motor or reload kit in any way will invalidate your motor warranty.

• **USE ONLY AEROTECH™ RMS™ RELOAD KITS AND MOTOR PARTS TO REFURBISH YOUR RMS™ MOTOR.** The AeroTech/RCS reload kits have been designed specifically for use in your particular AeroTech/RCS RMS™ motor. Use of imitation components may destroy your motor, rocket and payload and will invalidate your motor warranty. Only use AeroTech/RCS RMS™ reload kits intended for your specific AeroTech/RCS RMS™ motor. **DO NOT INTERCHANGE PARTS!** Do not use AeroTech/RCS RMS™ reload kits or motor components for any other purpose than to refurbish an AeroTech/RCS RMS™ motor.

• **DO NOT REUSE ANY OF THE DISPOSABLE PARTS OF THE RMS™ RELOAD KIT.** This includes the liner, nozzle and o-rings. These components have been designed for one use only and must be discarded after firing. Reuse can result in motor failure during subsequent operation and will invalidate your motor warranty.

• Motors are hot after firing. Although the RMS™ operates at a lower temperature than most disposable motors, the higher thermal conductivity of the aluminum motor parts may make it seem otherwise. If necessary to handle a motor before it has cooled down, use a rag or similar article.

• Read and follow the safety code of the Tripoli Rocketry Association (TRA) and comply with all federal, state and local laws in all activities involving high power rockets.

DO NOT OPEN RELOAD KIT UNTIL READY TO USE.

PARTS:

RMS™ HARDWARE

54mm aft closure	1
54/1280 case	1
54mm forward closure (std. reg. length or plugged reg. length)	1
54mm forward seal disk (1/8" thick flange)	1

RELOAD KIT

Nozzle (black plastic part)	1
Liner (2" O.D. black plastic tube)	1
Propellant grains	3
Fwd & aft o-rings (1/8" thick X 2" O.D.)	2
Seal disk o-ring (1/16" thick X 1-7/8" O.D.)	1
RMS-Plus™ smoke charge element (short solid part)	1
Smoke charge insulator (1-1/8" O.D. paper tube)	1
Smoke charge o-ring (1/8" thick X 1-1/8" O.D.)	1
Aft smoke charge spacer (short colored paper tube)	1
Forward smoke charge spacer (1-1/8" O.D. neoprene washer)	1

ITEMS NEEDED FOR USE:

- Synco™ Super Lube™ or other grease
- Hobby knife
- FirstFire or other igniter
- Wet wipes or damp paper towels

SAVE THE RELOAD KIT PLASTIC BAG FOR THE USED RELOAD PARTS. DISPOSE OF BAG AND PARTS PROPERLY.

Chapter 2. Case Assembly

2-1. **Fig.-4:** Using a hobby knife or similar tool, remove the burr (rough, raised edge) from both inside ends of the liner tube. Insert the nozzle into one end of the liner tube until the nozzle flange is seated against the liner.

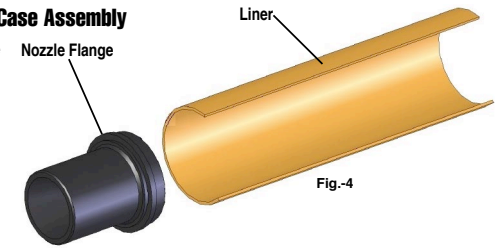

2-2. **Fig.-5:** Push the liner assembly, open end first, into the motor case until the nozzle protrudes from the case about 1-1/4". **NOTE:** A light coat of grease on the outside surface of the liner will facilitate installation and casing cleanup after motor firing.

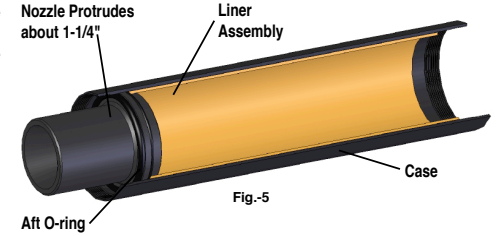

2-3. **Fig.-5:** Place the greased aft (1/8" thick X 2" O.D.) o-ring into the groove in the nozzle insert.

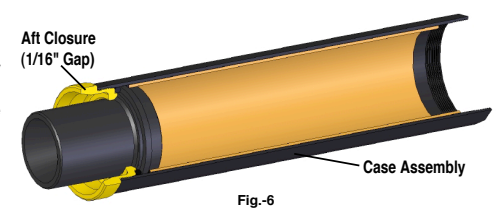

2-4. **Fig.-6:** Thread the aft closure into the motor case by hand until about 1/16" gap remains between the case and the closure. **NOTE:** Final tightening will be done after the other motor components are loaded into the case.

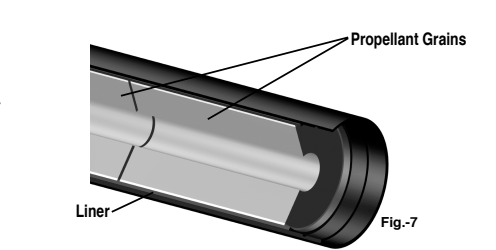

2-5. **Fig.-7:** Install the propellant grains into the liner. **NOTE:** Only two grains are shown in some illustrations for simplicity. RMS-54/1280 motors use three (3) grains.

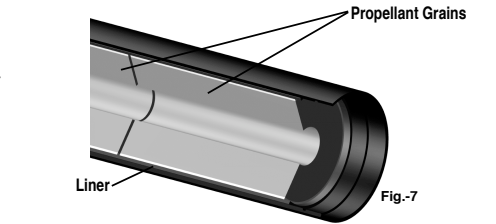

Chapter 1. Forward Closure Assembly

1-1. Apply a light coat of Synco™ Super Lube™ or other grease to all threads and all 4 o-rings. This will facilitate assembly and prevents the threads from seizing.

1-2. **Fig.-1:** Chamfer both inner edges of the smoke charge insulator with your fingernail. Assemble the RMS-Plus™ smoke charge element, smoke charge insulator, aft smoke charge spacer and smoke charge o-ring as shown. **NOTE:** It is **not** necessary to tape the smoke charge element or insulator, the hot gas seal is provided by the smoke charge o-ring alone.

1-3. **Fig.-2:** Insert the forward smoke charge spacer (1-1/8" O.D. neoprene washer) into the smoke charge cavity until it is seated against the forward end of the cavity. Apply a **light film** of grease to the inner circumference of the smoke charge cavity (but **not** the forward end of the cavity).

1-4. **Fig.-3:** Insert the smoke charge assembly shown in Fig.-1 into the smoke charge cavity, o-ring end first, until it is seated against the forward smoke charge spacer. **NOTES:** When using a **plugged** forward closure **ONLY**, fill the opening in the forward smoke charge spacer with grease prior to installing the smoke charge assembly, and install the smoke charge components in this order: Forward smoke charge spacer, smoke charge o-ring, smoke charge element, smoke charge insulator and aft smoke charge spacer.

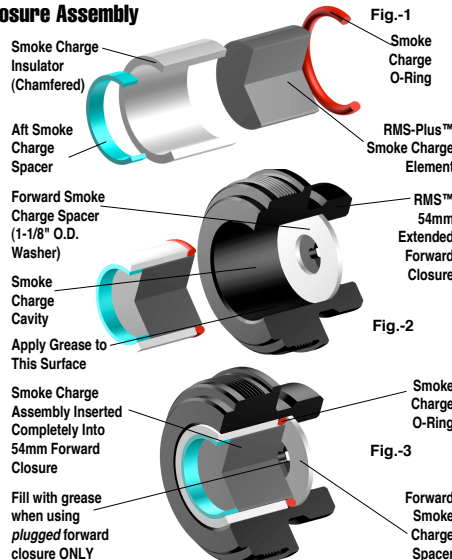

2-6. **Fig.-8:** Place the greased forward seal disk (1/16" thick X 1-7/8" O.D.) o-ring into the groove in the forward seal disk.

2-7. **Fig.-9:** Insert the smaller (o-ring) end of the seal disk into the open end of the liner tube until the seal disk flange is seated against the end of the liner.

2-8. **Fig.-10:** Place the greased forward (1/8" thick X 2" O.D.) o-ring into the case, seated against the forward seal disk.

2-9. **Fig.-11:** With the motor case held in a horizontal position, thread the completed forward closure assembly into the open end of the motor case by hand until it is seated against the case.

2-10. Finish tightening the aft closure by hand until it is seated against the case. **NOTE:** There will be some resistance to threading in the closure during the last 1/32" to 1/16" of travel. It is normal if a slight gap remains between the closure and the case after tightening and the grains rattle slightly inside the liner.

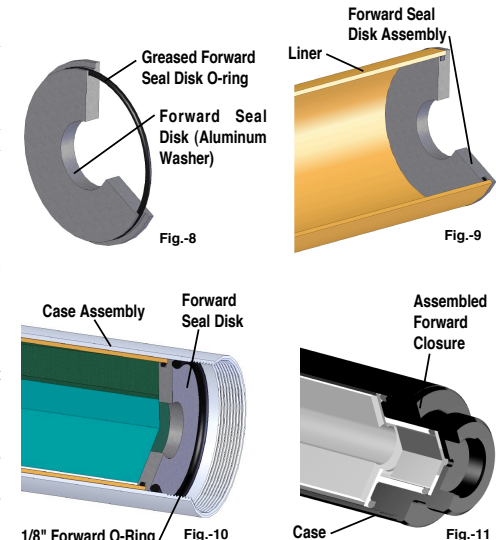

Chapter 3. Preparation For Flight

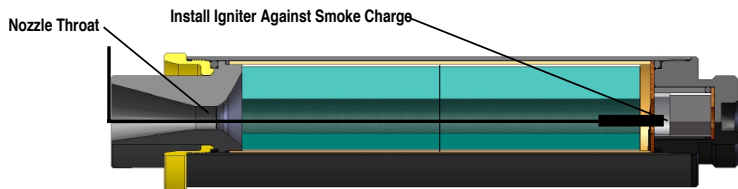

Fig.-12

- 3-1. Fig.-12: Insert the coated end of a FirstFire™, Firestar™ or other igniter through the nozzle throat until it stops against the delay charge element.
- 3-2. Secure the igniter to the nozzle with a piece of masking tape.
- 3-3. Install the motor into the rocket's motor mount tube. Ensure that the motor is securely retained in the rocket by using positive mechanical means to prevent it from being ejected during recovery system deployment.
- 3-4. Prepare the rocket's recovery system and then launch the rocket in accordance with the Tripoli Rocketry Association (TRA) Safety Code and National Fire Protection Association (NFPA) Code 1127.

Chapter 4. Post-Recovery Cleanup

NOTE: Perform motor clean-up as soon as possible after motor firing. Propellant and smoke charge residues become difficult to remove after 24 hours and can lead to corrosion of the metal parts. Place the spent motor components in the reload kit plastic bag and dispose of properly.

- 4-1. After the motor has cooled down, unthread and remove the forward and aft closures.
- 4-2. Remove the smoke charge assembly components from the forward closure and discard. Using wet wipes or damp paper towels, remove all smoke charge and propellant residue from the closures. **WARNING: FAILURE TO COMPLETELY REMOVE SMOKE CHARGE RESIDUE FROM THE INSIDE OF THE FORWARD CLOSURE CAN LEAD TO GAS LEAKAGE ON A SUBSEQUENT FLIGHT AND DAMAGE TO YOUR RMS MOTOR FORWARD CLOSURE AND ROCKET VEHICLE. NOTE:** Use of a plugged forward closure will eliminate the possibility of this failure mode.
- 4-3. Remove the liner from the casing by pushing on either end. Remove the forward seal ring from the liner. Discard the liner, nozzle and forward seal ring o-ring **ONLY**. Using wet wipes or damp paper towels, wipe the inside of the casing and the forward seal ring to remove all propellant residue. **DO NOT discard the forward seal ring!**
- 4-4. Apply a light coat of grease to all threads and the inside of the motor case. Reassemble metal parts and store motor in a dry place.

Chapter 5. First Aid

For a minor burn, apply a burn ointment. For a severe burn, immerse the burned area in ice water at once and see a physician as quickly as possible. In the unlikely event of oral ingestion of the propellant, induce vomiting and see a physician as quickly as possible. The AeroTech/RCS composite propellant consists primarily of ammonium perchlorate and a rubber-like plastic elastomer.

Chapter 6. Disposal

Damaged or defective reload kits should be returned to RCS.

Chapter 7. Fire Safety

Tests show that the pyrotechnic components of RMS™ reload kits will not explode in fires and normally will not ignite unless subjected to direct flame and then will burn slowly. Use water to fight any fires in which AeroTech RMS™ reload kit pyrotechnic components may become involved: Direct the water at the AeroTech RMS™ reload kit pyrotechnic components to keep them below their 550 deg. F autoignition temperature. Foam and carbon dioxide fire extinguishers will NOT extinguish burning propellants of the type used in RMS™ reload kit pyrotechnic components. Keep reload kit pyrotechnic components away from flames, sources of heat and flammable materials.

Disclaimer and Warranty

NOTICE: As we cannot control the storage and use of our products, once sold we cannot assume any responsibility for product storage, transportation or usage. RCS shall not be held responsible for any personal injury or property damage resulting from the handling, storage or use of our product. The buyer assumes all risks and liabilities therefrom and accepts and uses AeroTech/RCS products on these conditions. No warranty either expressed or implied is made regarding AeroTech/RCS products, except for replacement or repair, at RCS's option, of those products which are proven to be defective in manufacture within one year from the date of original purchase. For repair or replacement under this warranty, please contact RCS. Proof of purchase will be required. Note: Your state may provide additional rights not covered by this warranty.

Division of RCS Rocket Motor Components, Inc.

HIGH-POWER RMS™

Reloadable Motor System

**DO NOT OPEN
RELOAD KIT
UNTIL READY
TO USE**

With **Advanced Delay Sealing System**

RMS™ 54/1280 WARP-9™

Typical Time-Thrust Curve:

Certified By The Tripoli Rocketry Association

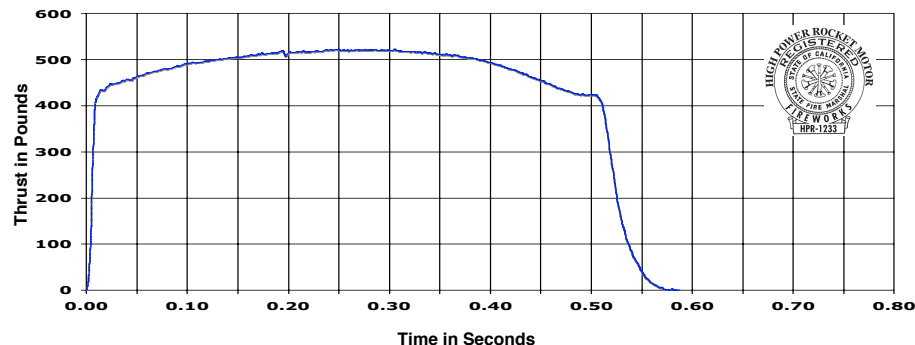

THIS PACKAGE CONTAINS ONE RMS-PLUS™ RELOAD KIT:

J1999N-P (54/1280)

NOTE: Warp-9 reload kits do not include an ejection charge. Warp-9 motors must be used in conjunction with a timer, altimeter or radio-actuated recovery system.

N = Warp-9™

The reload kit shown above is **ONLY** for use in AeroTech/RCS RMS-54/1280 High-Power motors.

RMS-54/1280 WARP-9 RELOAD KIT DATA

Hardware Desig.	Performance Desig.	Total Impulse (Max.)	Propellant Wt.	Loaded Motor Wt.
RMS™-54/1280	J1999N	1150 N-sec	515.2 g (1.135 lb)	1100 g (2.42 lb)

RMS-54/1280 HARDWARE DATA

Hardware Designation	Motor Diameter	Motor Length	Hardware Weight	Reload Used
RMS™-54/1280	2.125" (54mm)	12.82"	338 g (0.744 lb)	J1999N

NOTE: Total impulse shown is optimum. Motor lengths are measured from end of aft closure to end of forward closure.

NOTE: SALE TO PERSONS UNDER 21 YEARS OF AGE PROHIBITED BY FEDERAL LAW. WARNING-FLAMMABLE: Read Instructions Before Use. KEEP OUT OF REACH OF CHILDREN. FOR USE ONLY BY CERTIFIED HIGH-POWER USERS 21 YEARS OF AGE OR OLDER. DO NOT SMOKE when loading these motors or use in the vicinity of open flames.