

54MM KOSDON BY AEROTECH™ (KBA™) ANIMAL-COMPATIBLE™

Assembly and Operation Instructions

READ THIS BEFORE YOU BEGIN:

• Study the illustrations and sequence of assembly. **THE SEQUENCE OF ASSEMBLY IS EXTREMELY IMPORTANT. READ ALL INSTRUCTIONS BEFORE USE. USE KBA LOADED MOTORS AND RELOAD KITS ONLY IN ACCORDANCE WITH ALL INSTRUCTIONS.** Review the parts list and become familiar with all parts before assembly. **IF ANY PARTS ARE MISSING OR DAMAGED, CONTACT RCS AT 1-435-865-7100.**

• **DO NOT USE ANY PARTS OF THE KBA SYSTEM THAT ARE DAMAGED IN ANY WAY.** If in doubt, contact RCS at the number above for assistance.

• **DO NOT MODIFY THE MOTOR IN ANY WAY.** Modification of the motor or the reload kit parts could result in motor failure, lead to the destruction of both your rocket and motor and may cause personal injury, death and/or property damage. Modification of the motor or reload kit in any way will invalidate your motor warranty.

• **USE ONLY KBA RELOAD KITS AND MOTOR PARTS TO REFURBISH YOUR KOSDON OR ANIMAL MOTOR.** The KBA reload kits have been designed specifically for use in your particular Kosdon or Animal motor. Use of imitation components may destroy your motor, rocket and payload and will invalidate your motor warranty. Only use KBA reload kits intended for your specific Kosdon or Animal motor. **DO NOT INTERCHANGE PARTS!** Do not use KBA reload kits or motor components for any other purpose than to refurbish an Kosdon or Animal motor.

• **DO NOT REUSE ANY OF THE DISPOSABLE PARTS OF THE KBA RELOAD KIT.** This includes the liner and o-rings. These components have been designed for one use only and must be discarded after firing. Reuse can result in motor failure during subsequent operation and will invalidate your motor warranty.

• Motors are hot after firing. Although the KBA motor operates at a lower temperature than most disposable motors, the higher thermal conductivity of the aluminum motor parts may make it seem otherwise. If necessary to handle a motor before it has cooled down, use a rag or similar article.

• Read and follow the safety code of the Tripoli Rocketry Association (TRA) and comply with all federal, state and local laws in all activities involving high power rockets.

DO NOT OPEN RELOAD KIT UNTIL READY TO USE.

PARTS:

KOSDON/ANIMAL 54MM MOTOR HARDWARE

54-2550 Kosdon or Animal case	1
54mm Animal forward bulkhead	1
54mm Animal graphite nozzle w/.660" throat	1
54mm nozzle washer (steel)	1
54mm snap rings	2

KBA ANIMAL-COMPATIBLE RELOAD KIT

Propellant grains	6
Liner (long phenolic tube)	1
Silicone o-rings (1-7/8" O.D. X 1/8")	2
Smoke element (short solid part)	1

ITEMS NEEDED FOR USE:

- Synco™ Super Lube™, Dow Corning 111 or other grease
- FirstFire™ or other igniter with extended leads
- Snap ring pliers
- 3/8-16 threaded bolt
- 1-7/8" O.D. wooden dowel
- Wet wipes or damp paper towels
- Disposable rubber gloves (Mojave Green kits)

SAVE THE RELOAD KIT PLASTIC BAG FOR THE USED RELOAD PARTS. DISPOSE OF BAG AND PARTS PROPERLY.

Chapter 1. Nozzle Assembly

1-1. Apply a light coat of Synco™ Super Lube™ or other grease to both o-rings. This will facilitate assembly and promotes proper sealing of the o-rings.

1-2. **Fig.-1:** Place the greased nozzle o-ring (1-7/8" O.D. X 1/8") into the groove in the graphite nozzle.

1-3. **Fig.-1:** Put grease on your index finger and wipe a film of grease on the I.D. of both ends of the case. Using a twisting motion, install the nozzle into the end of the case that has the external snap ring groove (if applicable). Note from the drawing the proper orientation of the nozzle.

1-4. **Fig.-2:** Install the steel nozzle washer in the case, seated against the graphite nozzle.

1-5. **Fig.-2:** Using the snap ring pliers, install a 54mm snap ring into the internal groove on the nozzle end of the case. To prevent eye injury if a snap ring slips out of the pliers, wear eye protection and hold the motor casing at a right angle to yourself.

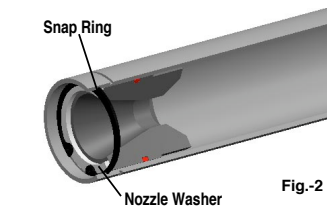
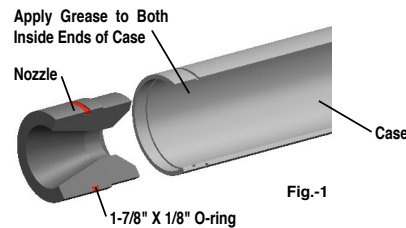

Chapter 2. Case Assembly

2-1. **Fig.-3:** Install the propellant grains into the liner until they are equally spaced from both ends of the liner. **NOTE:** The use of disposable rubber gloves when handling Mojave Green propellant grains is strongly recommended.

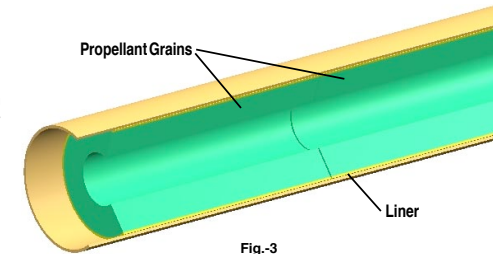

2-2. **Fig.-4:** Install the smoke element into one end of the liner until it is slightly below flush with the end of the liner. **NOTE:** The inhibitor-coated end of the smoke element must face away from the propellant grains.

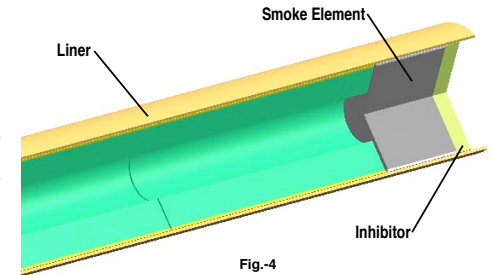

2-3. **Fig.-5:** Install the liner assembly into the open end of the case until the aft end of the liner is seated in the nozzle step and the propellant grains are seated against the nozzle. **NOTE:** A liberal coat of grease on the outside of the liner will facilitate installation and casing cleanup after firing.

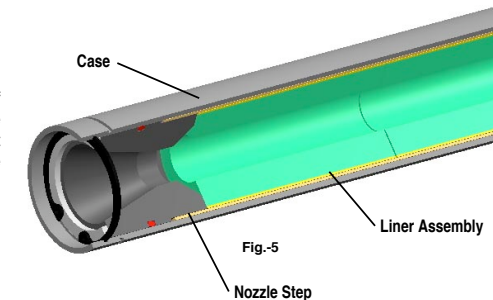

2-4. **Fig.-6:** Install a 1-7/8" O.D X 1/8" o-ring into the groove in the forward bulkhead.

2-5. **Fig.-6:** Using a twisting motion, install the forward bulkhead into the forward end of the motor case until it is seated against the liner. Note from the drawing the proper orientation of the forward bulkhead.

2-6. **Fig.-6:** Using the snap ring pliers, install a 54mm snap ring into the internal groove on the bulkhead end of the case. To prevent eye injury if a snap ring slips out of the pliers, wear eye protection and hold the motor casing at a right angle to yourself. **NOTE:** It is normal if the grains rattle slightly inside the liner.

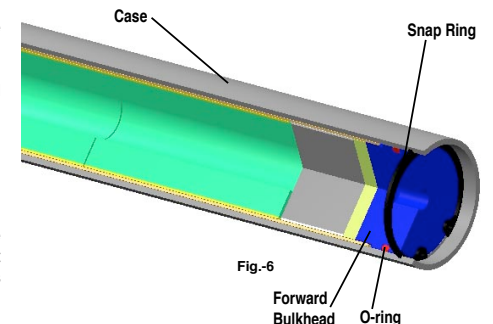

Chapter 3. Preparation For Flight

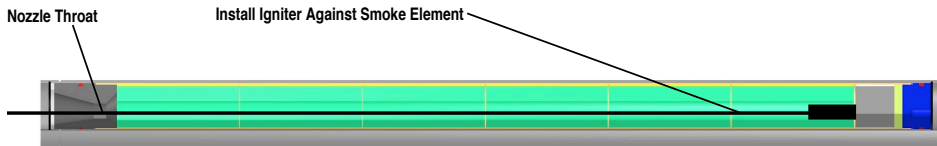

Fig.-7

- 3-1. Install the motor into the rocket's motor mount tube. Ensure that the motor is securely retained in the rocket by using positive mechanical means to prevent it from being ejected at the time of recovery system deployment.
- 3-2. **Fig.-7:** Insert the coated end of a FirstFire™ or other suitable igniter through the nozzle throat until it stops against the smoke element.
- 3-3. Prepare the rocket's recovery system and then launch the rocket in accordance with the kit manufacturer's instructions. the Tripoli Rocketry Association (TRA) Safety Code and National Fire Protection Association (NFPA) Code 1127.

Chapter 4. Misfires

If a misfire occurs and a loaded KBA motor does not ignite for any reason within five seconds of pressing the launch button, release the launch button and remove the safety key from the electrical launch controller. **WAIT ONE MINUTE** before approaching or allowing anyone else to approach the rocket. Keep your fingers and hands out from underneath the rocket and away from the possible path of the exhaust jet. Do not place any part of your body over the launch pad. Disconnect the igniter clips from the electrical igniter. Carefully remove the igniter from the motor, and install a new igniter and repeat the launching process.

Chapter 5. Post-Recovery Cleanup

NOTE: Perform motor clean-up as soon as possible after motor firing. Propellant and delay residues become difficult to remove after 24 hours and can lead to corrosion of the metal parts. Place the spent motor components in the reload kit plastic bag and dispose of properly.

- 5-1. After the motor has cooled down, remove the snap rings and the aft steel washer from the case.
- 5-2. Thread a 3/8-16 bolt into the hole in the forward bulkhead. Grasp the exposed end of the bolt and remove the bulkhead using a twisting and pulling motion.
- 5-3. Using a wooden dowel or similar instrument inserted into the forward bulkhead end of the case, gently push the nozzle and liner out of the casing. Discard the liner.
- 5-4. Remove and discard the nozzle o-ring and the forward bulkhead o-ring. Using wet wipes or damp paper towels, wipe the surfaces of the casing, nozzle and forward bulkhead to remove all propellant and smoke element residue. **WARNING: FAILURE TO COMPLETELY REMOVE PROPELLANT AND SMOKE ELEMENT RESIDUE FROM THE HARDWARE CAN LEAD TO GAS LEAKAGE ON A SUBSEQUENT**

Kosdon by AeroTech Division
RCS Rocket Motor Components, Inc.
Cedar City, UT 84720
www.aerotech-rocketry.com

FLIGHT AND DAMAGE TO YOUR KOSDON/ANIMAL MOTOR HARDWARE AND ROCKET VEHICLE.

- 5-5. Apply a light coat of grease to the exterior of the forward bulkhead and the inside of the motor case. Store motor parts in a dry place. **DO NOT** store ungreased nozzle in casing which can lead to severe corrosion of the case.

Chapter 6. First Aid

DANGER: DO NOT INGEST PROPELLANT OR BREATHE EXHAUST FUMES! WASH HANDS AFTER HANDLING MOJAVE GREEN PROPELLANT AND BEFORE EATING. For a minor burn, apply a burn ointment. For a severe burn, immerse the burned area in ice water at once and see a physician as quickly as possible. In the unlikely event of oral ingestion of the propellant, induce vomiting and see a physician as quickly as possible. The KBA/RCS composite propellant consists primarily of Ammonium Perchlorate and a rubber-like plastic elastomer. Mojave Green propellant also contains Barium Nitrate.

Chapter 7. Disposal

Damaged or defective reload kits should be returned to RCS.

Chapter 8. Fire Safety

Tests show that the pyrotechnic components of KBA reload kits will not explode in fires and normally will not ignite unless subjected to direct flame and then will burn slowly. Use water to fight any fires in which KBA reload kit pyrotechnic components may become involved: Direct the water at the KBA reload kit pyrotechnic components to keep them below their 550 deg. F autoignition temperature. Foam and carbon dioxide fire extinguishers will NOT extinguish burning propellants of the type used in KBA reload kit pyrotechnic components. Keep reload kit pyrotechnic components away from flames, sources of heat and flammable materials.

Disclaimer and Warranty

NOTICE: As we cannot control the storage and use of our products, once sold we cannot assume any responsibility for product storage, transportation or usage. RCS and/or Kosdon Enterprises shall not be held responsible for any personal injury or property damage resulting from the handling, storage or use of our product. The buyer assumes all risks and liabilities therefrom and accepts and uses KBA/RCS products on these conditions. No warranty either expressed or implied is made regarding KBA/RCS products, except for replacement or repair, at RCS's option, of those products which are proven to be defective in manufacture within one year from the date of original purchase. For repair or replacement under this warranty, please contact RCS. Proof of purchase will be required. Note: Your state may provide additional rights not covered by this warranty.

P/N K08101 Rev. 11/12/08
Made in U.S.A.

©2008 RCS Rocket Motor Components, Inc., All rights reserved

54-2550 KOSDON BY AEROTECH™ ANIMAL-COMPATIBLE™ RELOAD KIT

TYPICAL TIME-THRUST CURVES:

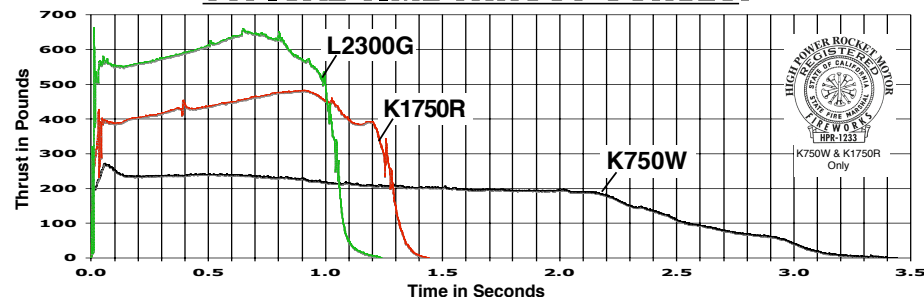

THIS PACKAGE CONTAINS ONE KOSDON BY AEROTECH (KBA™) ANIMAL-COMPATIBLE RELOAD KIT:

- K750W-P
- K1750R-P
- L2300G-P

The reload kits shown above are **ONLY** for use in Kosdon/Animal 54mm High-Power motors.

W = White Lightning™, R = Redline™, G = Mojave Green™

NOTE: 54mm KBA reload kits are sold in a "plugged" configuration only and do not include an ejection charge. 54mm KBA motors must be used in conjunction with a timer, altimeter or radio-actuated recovery system.

KOSDON BY AEROTECH 54-2550 RELOAD KIT DATA

Hardware Desig.	Performance Desig.	Total Impulse (Typ.)	Propellant Wt.	Loaded Motor Wt.
Kosdon/Animal 54-2550	K750W	2560 N-sec	1315 g (2.90 lb)	2620 g (5.77 lb)
Kosdon/Animal 54-2550	K1750R	2460 N-sec	1253 g (2.76 lb)	2560 g (5.64 lb)
Kosdon/Animal 54-2550	L2300G	2722 N-sec	1310 g (2.89 lb)	2624 g (5.78 lb)

KOSDON/ANIMAL 54-2550 HARDWARE DATA

Hardware Desig.	Throat Dia.	Motor Diameter	Motor Length	Hardware Weight	Reloads Used
Kosdon/Animal 54-2550	.660"	2.125" (54mm)	28.66"	1019 g (2.24 lb)	K750W, K1750R, L2300G

NOTE: SALE TO PERSONS UNDER 21 YEARS OF AGE PROHIBITED BY FEDERAL LAW. DANGER-POISON: Mojave Green Propellant Contains Barium Nitrate. DO NOT INGEST PROPELLANT OR BREATHE EXHAUST FUMES. WARNING-FLAMMABLE: Read Instructions Before Use. KEEP OUT OF REACH OF CHILDREN. FOR USE ONLY BY CERTIFIED HIGH-POWER USERS 21 YEARS OF AGE OR OLDER. DO NOT SMOKE when loading these motors or use in the vicinity of open flames.