

ASTROBEE D

ADVANCED MODEL ROCKET

Assembly and Operation Instructions

BEFORE YOU BEGIN:

- Study the illustrations and sequence of assembly. The sequence of assembly is important. Review the parts list and become familiar with all parts before assembly. If any parts are missing or damaged, contact RCS at 1-435-865-7100 or email at warranty@erotech-rocketry.com
- **DO NOT MODIFY THE DESIGN OF THE ROCKET.** Changes to the design of the rocket such as, but not limited to, reducing the fin size, shortening the body tube, or modifying the motor tube assembly can adversely affect the flight stability of the rocket.
- Only use AEROTECH™ Composite Model Rocket Motors in this model rocket. See Motor Matrix for recommended AEROTECH™ motors.

Read and follow the Model Rocket Safety Code of the National Association of Rocketry (NAR) and comply with all federal, state and local laws in all activities with model rockets.

PARTS:

Thrust Ring (7/16"/11mm)	(14010)	1
Thrust Ring Flange (1/16"/1.6mm)	(14011)	1
Motor Tube	(12912)	1
Motor Hook	(19001)	1
FIN-LOK Rings (4 Fin)	(19344)	2
Centering Rings (2-17/32"/64mm)	(16629)	3
Fins	(11715)	4
Cooling Mesh	(19011)	1
Ejection Gas Baffle	(19030)	1
Screw Eye	(19015)	2
Shock Cord (8')	(17388)	2
Lower Body Tube (Slotted)	(12628)	1
Upper Body Tube (Launch Lug)	(12629)	1
Bulkhead Disk (1/16"/1.6mm)	(16609)	1
Coupler Tube (6"/15cm)	(12606)	1
Launch Lugs	(19035)	2
Nose Cone	(11261)	1
Decal Sheet	(18015)	1
30" Parachute (Lower Body)	(13030)	1
22" Parachute (Upper Body)	(13022)	1
Scale Plastic Launch Lug Piece	(18915)	1
Scale Plastic Antenna Mounts	(18925)	2
Aluminum Antenna Tubes	(18930)	2
Scale Plastic Fasteners	(18935)	12
Chrome Adhesive Band	(18940)	1
'F' Spacer Tube (1")	(14003)	1
Scale Drawing	(19815)	1
Instructions	(19915)	1

Additional Tools Required:

Pliers

ASSEMBLY INSTRUCTIONS: (Use medium viscosity cyanoacrylate cement.)

COMPLETED ASTROBEE D ADVANCED MODEL ROCKET

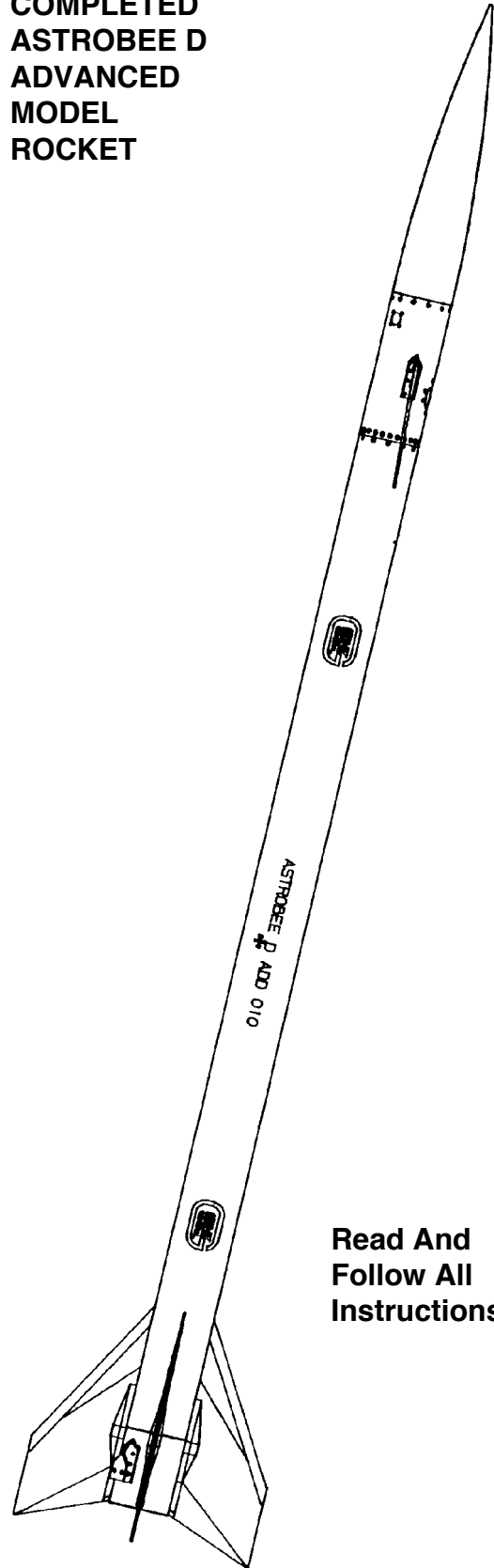

**Read And
 Follow All
 Instructions**

Astrobee D and the Aerojet logo are trademarks of Gencorp and Gummiwerke AG.

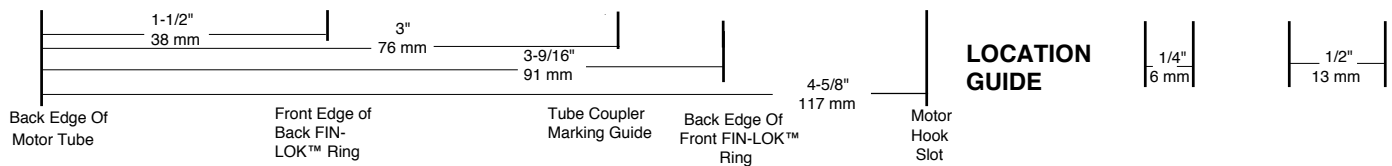

MOTOR TUBE ASSEMBLY

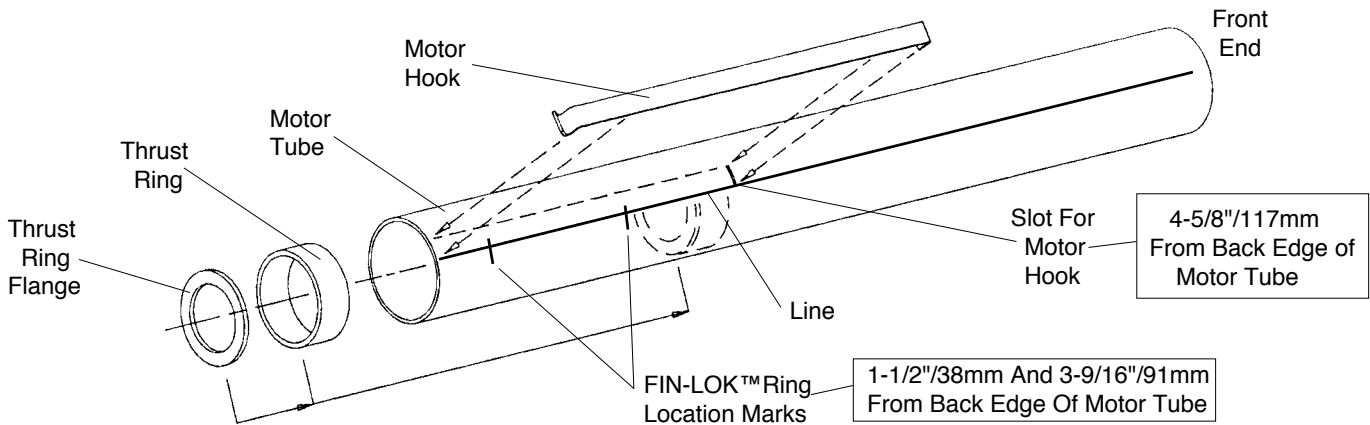

1. Cement the thrust ring flange (1/16"/1.6 mm thick) to the thrust ring (7/16"/11 mm long). Set the thrust ring assembly aside to dry.
2. Find the line drawn along the side of the motor tube. Using the Location Guide printed along the top edge of this instruction sheet, cut a 1/4" (6 mm) long slot 4-5/8" (117mm) from the back end of the motor tube and next to the line on the motor tube as shown.
3. Using the Location Guide, make a mark along the motor tube line 3-9/16" (91mm) from the **back end** of the motor tube. This mark locates where the **back edge** of the front FIN-LOK™ ring will be. Make another mark 1-1/2" (38mm) from the **back end** of the motor tube. This mark locates where the **front edge** of the rear most FIN-LOK™ ring will be.
4. Insert the tab of the motor hook into the slot cut into the motor tube. **Use a small dowel to apply several drops of cement around the inside of the motor tube just behind where the motor hook comes through the motor tube wall.** Then, with the thrust ring flange facing the back of the motor tube, insert the thrust ring assembly into the motor tube until it stops, against the motor hook tab.

FIN-LOK™ ASSEMBLY

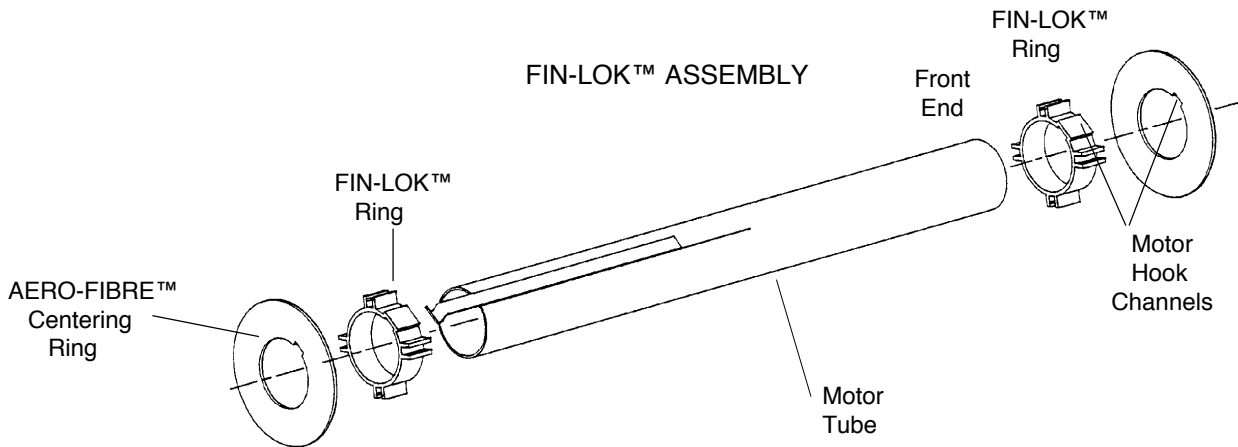

NOTE: FROM THIS POINT ON, DO NOT USE ANY CEMENT UNTIL REACHING ASSEMBLY STEP 5.

1. With their motor hook channels aligned with the motor hook, slide a FIN-LOK™ ring and then an AERO-FIBRE™ centering ring over the **front end** of the motor tube. Push on the centering ring until the **back edge** of the FIN-LOK™ ring is moved to the forward most mark made in Step 3 above. (**NOTE:** The rings are designed to be a tight fit on the motor tube. If the rings are difficult to slide onto the motor tube, round the inside edges of the rings with sandpaper. If the FIN-LOK™ rings need to be turned
2. Slide the other FIN-LOK™ ring and then a centering ring over the **back end** of the motor tube. Push on the centering ring until the **front edge** of the FIN-LOK™ ring is at the rear-most mark made in Step 3.
3. Using the line on the motor tube as a guide, gently twist the back centering ring slightly until the fin locks of the back FIN-LOK™ ring are aligned with the fin locks of the front FIN-LOK™ ring.

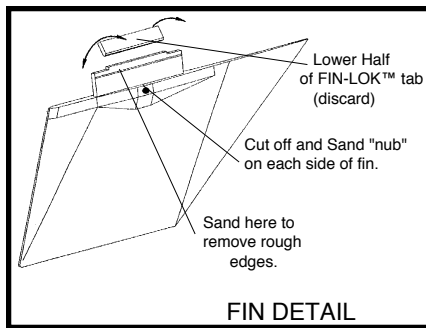

FIN-LOK™ ASSEMBLY (CONT.)

Front End

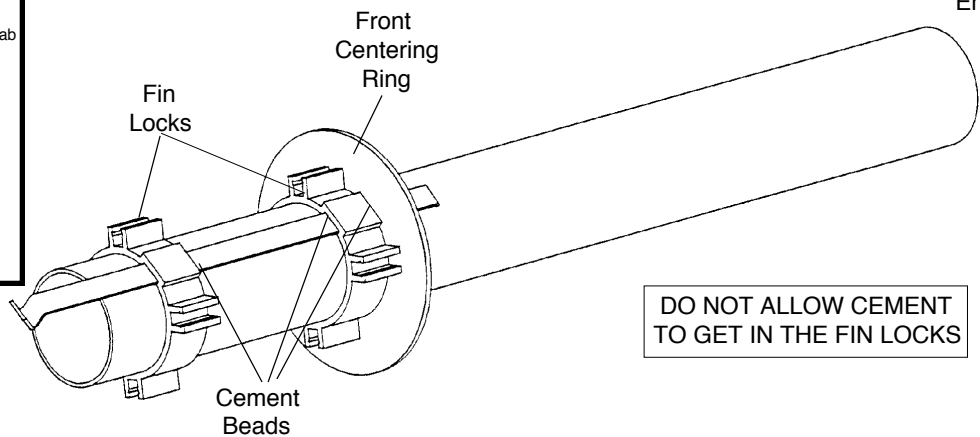

DO NOT ALLOW CEMENT TO GET IN THE FIN LOCKS

- Use a pair of pliers to snap off the lower half of the FIN-LOK™ tab from each of the four (4) fins as shown. Discard the pieces that were broken off. Sand the edge of the tabs to remove any rough edges from where the lower half of the fin tabs were removed. Cut and sand the nub on each side of the fin until smooth.
- Test the proper positioning and alignment of the FIN-LOK™ rings by snapping the fins into the fin locks. If any fin does not snap into place, check to see that each FIN-LOK™ ring is the correct distance from the back end of the motor tube and that the fin has no plastic flashing left from production that may be preventing a proper fit. Remove any plastic flashing with a hobby knife or sandpaper. After making any adjustments, carefully remove the fins **and the back centering ring**. Check that the front centering ring is still positioned next to and touching the front FIN-LOK™ ring.
- Apply a bead of cement where the front centering ring meets the motor tube. Without getting cement into any of the finlocks, apply cement only to the areas BETWEEN the finlocks where the front FIN-LOK™ ring meets the front centering ring and the motor tube.
- Without getting cement into any of the fin locks, apply cement only to the areas BETWEEN the fin locks where only the **front edge** of the back FIN-LOK™ ring meets the motor tube. DO NOT apply cement to the back edge of the back FIN-LOK™ ring. (**NOTE:** The unique AEROTECH FIN-LOK™ fin mounting system carries and distributes aerodynamic and thrust loads throughout an integrated rocket structure in a manner found in large aerospace vehicles. Loads are primarily borne by structural members and not cement.)
- Apply a bead of cement around the motor hook forward of the front centering ring.

LABYRINTH™ ASSEMBLY

DO NOT CEMENT COOLING MESH INTO MOTOR TUBE

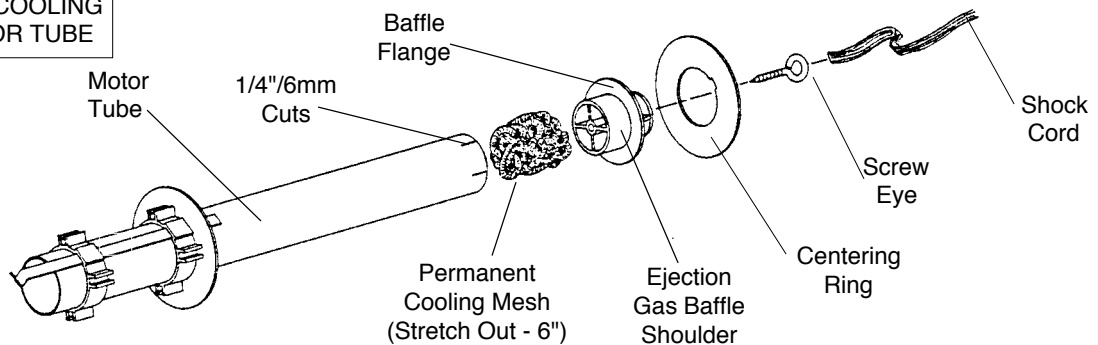

- Make four 1/4" (6mm) long cuts, 90 degrees apart, in the front end of the motor tube.
- Stretch out the cooling mesh to about 6" (15cm) in length. Insert the cooling mesh into the **front end** of the motor tube. (**NOTE:** Do **not** cement the mesh into the motor tube.)
- Apply a **thin film** of cement to the front 2/3rd's of the shoulder of the ejection gas baffle and insert the baffle shoulder into the front end of the motor tube.
- Apply beads of cement where the baffle meets the motor tube and into each of the cuts in the motor tube.**
- Apply cement to the front surface of the baffle flange and place an AERO-FIBRE™ centering ring over the front end of the baffle so it rests upon the baffle flange.
- Screw the screw eye all the way into the hole at the front end of the baffle. Securely tie an end of the shock cord to the screw eye with a square knot. (**CAUTION:** Do **not** put cement on the knot of the shock cord. Cement will weaken the shock cord.)

LOWER BODY PREPARATION

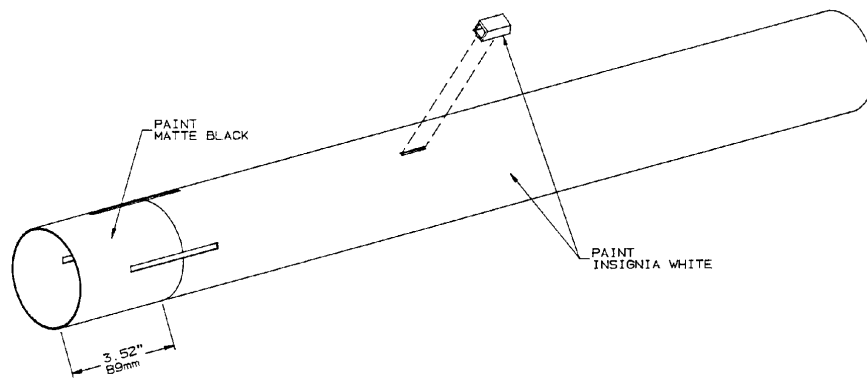

1. For a smooth finish, fill in the spiral in the body tube seam with a filler material. Sand the seam flush with the surface of the body tube.
2. Using a hobby knife, carefully remove any body tube material from the slot where the launch lug is to be attached.
3. Lightly sand the surface of the lower body tube around the launch lug slot.
4. Apply cement to the base of a launch lug. With the sloping portion of the launch lug toward the front of the lower body tube, insert the tab on the bottom of the lug into the pre-cut launch lug slot in the lower body tube.
5. Apply a base primer coat of paint to the lower body tube. After the base coat has dried paint the entire body tube insignia white. Allow to dry thoroughly. The back 3.52" (89mm) of the body tube is painted matte black. Mask off and paint this area accordingly.

UPPER BODY PREPARATION AND ASSEMBLY

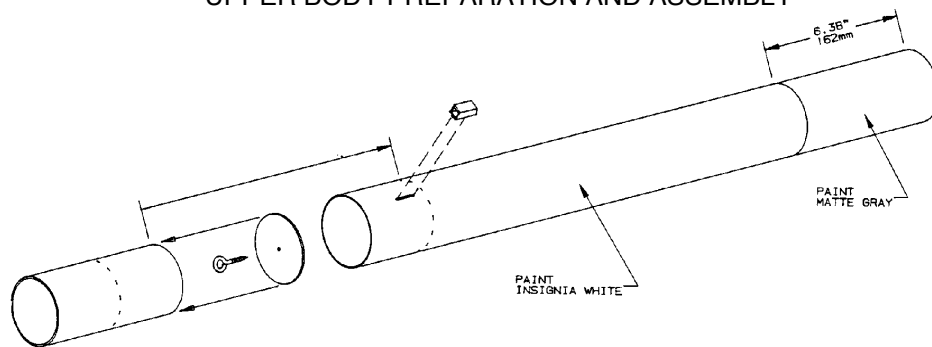

1. For a smooth finish, fill in the spiral in the body tube with a filler material. Sand the filler material flush with the surface of the body tube.
2. Using a hobby knife, carefully remove any body tube material from the slot where the launch lug is to be attached.
3. Lightly sand the surface of the upper body tube around the launch lug slot. Apply cement to the base of the remaining launch lug. With the sloping portion of the launch lug toward the front of the upper body tube, insert the tab on the bottom of the lug into the pre-cut launch lug slot in the upper body tube.
4. Apply a base primer coat of paint to the upper body tube. After the base coat has dried paint the entire body tube insignia white. Allow to dry thoroughly. The forward 6.38" (162mm) of the body tube is painted matte gray. Mask off and paint this area accordingly. Let dry.
5. Screw the other screw eye all the way into the hole in the bulkhead (1/16"1.6mm thick). Apply a bead of cement where the screw eye meets the bulkhead.
6. Pass the free end of the remaining shock cord through the coupler tube (6"/15cm long) and securely tie it to the screw eye attached to the bulkhead with a square knot. (CAUTION: Do not put cement on the knot of the shock cord. Cement will weaken the shock cord.)
7. Cement the bulkhead plate to the end of the coupler tube.
8. Make a pencil mark 3" (76mm) from an end of the coupler tube. Lightly sand the surface of the coupler tube between the mark and the bulkhead. Use a small dowel to apply a bead of cement around the inside of the upper body tube about 1" (25mm) from the back end of the tube. Then slide the coupler into the upper body tube up to the pencil mark on the coupler tube.

LOWER BODY AND FIN ASSEMBLY

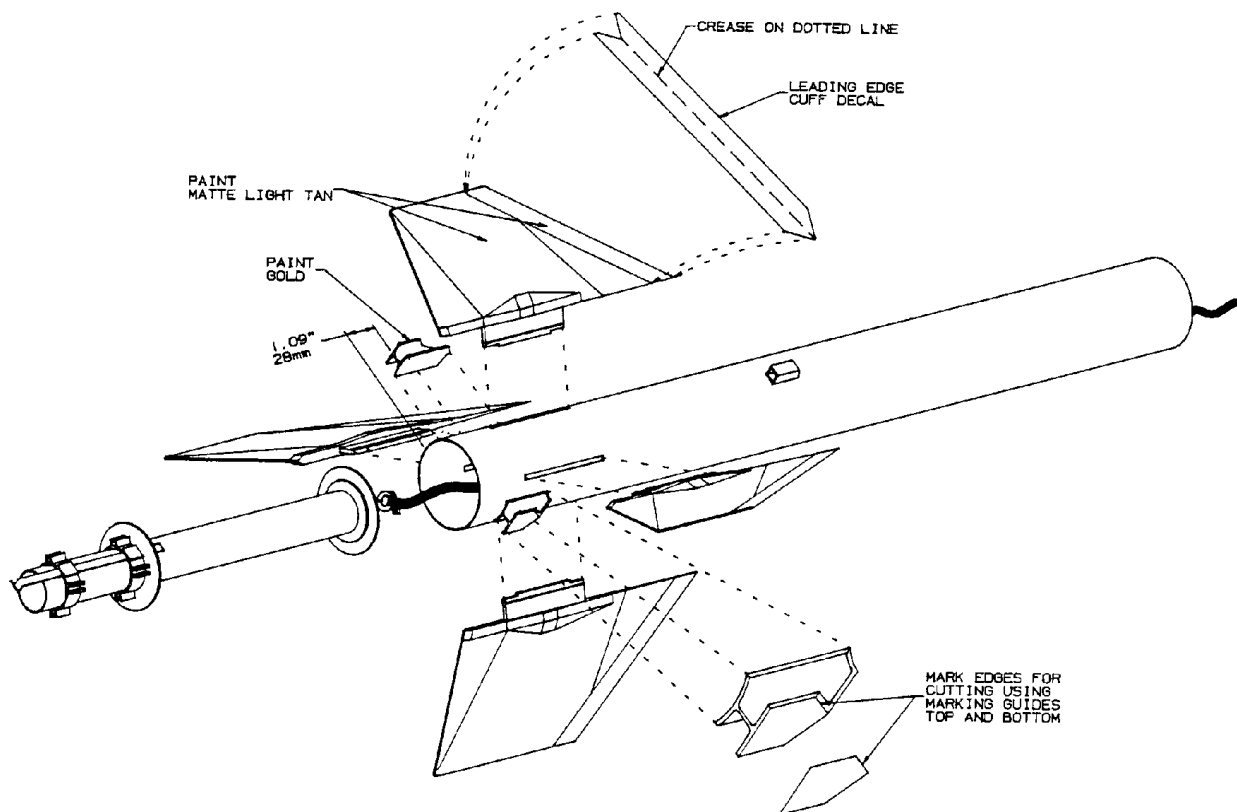

- Mask off the FIN-LOK tab on each of the four Astrobee D fins. Carefully wash the fins in a detergent/soap bath to remove any oils left over from the molding process. On the decal sheet locate the 4 leading edge cuffs (labelled 'M'). Cut these cuffs and crease each of them along the center dashed line. Remove the backing from a cuff decal. Center the dashed line over the leading edge apex of the fin. (Review instruction drawing for proper orientation.) Press the center of the decal to the leading edge of the fin. Press down the sides of the cuff decal over the front of the fin. Be sure to check the position of the decal as this is done and press out any air pockets which may be under the decal. Repeat this step for the remaining fins. Paint each fin matte light tan. Set aside to dry.
- Using a hobby knife, carefully remove any body tube material that may still be attached to any pre-cut slots in the body tube.
- Insert the loose end of the shock cord and then the motor tube assembly into the back of the rocket body tube as shown. Position the motor tube assembly so that the fin locks are located under and visible through the body tube's pre-cut fin slots.
- Apply cement along the full length of the fin root of a fin (area of the fin that makes contact with the outside surface of the lower body tube). Carefully insert the fin through a slot in the body tube and snap the fin into place. Repeat this process for the other three fins. (NOTE: Each fin should be snug against the body tube.)
- Through the back of the body tube, apply cement where the fin tabs meet the motor tube, fin locks, front centering ring and body tube. Through the front end of the body tube, apply cement where the baffle assembly centering ring meets the inside surface of the body tube.
- Locate the length of plastic launch lug rail. Using a model knife or razor saw cut off two pieces 1 15/16" (49mm) long. Cut out the aft launch lug top and bottom marking guides. Trace their patterns on to each of the pieces of launch lug rail previously cut. Using a sharp model knife, cut these two pieces to the proper shape. Wash these parts in a detergent/soap bath. Rinse and let dry. Paint both pieces gold.
- Note the location of the scale launch lugs on the lower body tube. Carefully cut out the aft launch lug marking guide. Remove the inner outlined area inside the guide using a model knife. Place the marking guide between two fins located 90 degrees around either side of the body tube from the flight launch lug (See drawing). Using a pencil, lightly mark the outline of the aft launch lug rail on the end of the body tube. Apply cement to the bottom of one of the launch lug rails. Press in place and hold until the cement sets. Repeat this step for the remaining launch lug rail.

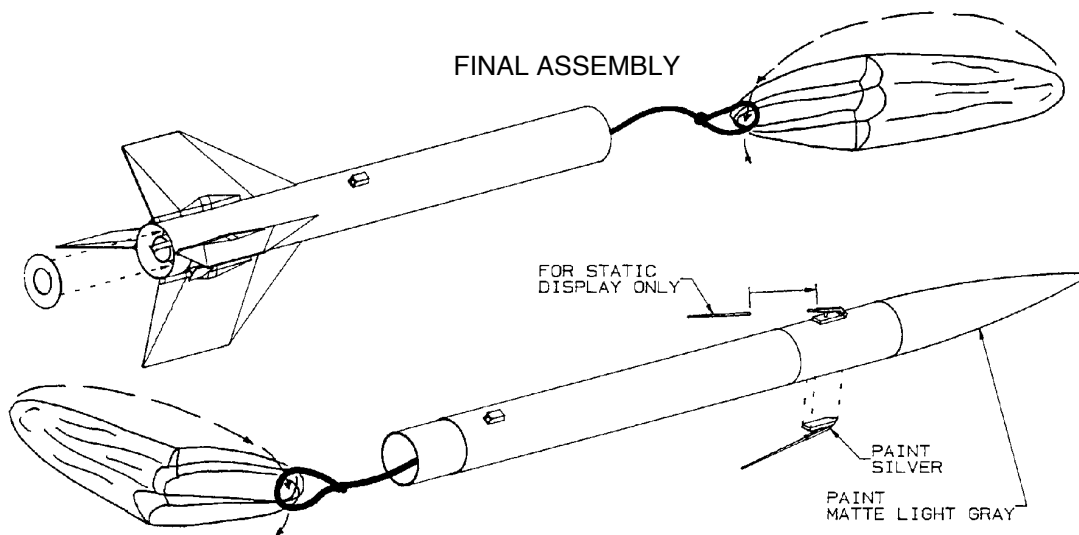

1. Slide the remaining centering ring over the back of the motor tube and motor hook and push it against the back FIN-LOK ring. Apply a bead of cement where the centering ring meets the body tube.
2. Clean the nose cone with a damp cloth. Mask off the nose cone shoulder to prevent any paint from getting on it. Paint the nose cone with a primer coat of paint (gray or white). Let the primer dry. Paint the nose cone with matte light gray paint. (CAUTION: Make sure the paint is compatible with high impact polystyrene plastic). Once the paint is dried, cement the nose cone into the forward end of the upper body tube.
3. Take the two plastic antenna shoe pieces and wash them in a detergent/soap bath. Rinse and let dry. Paint both pieces silver. Let paint dry.
4. Cut out the payload section antenna location and decal placement guide. Carefully cut out the areas marked "Antenna Location" on the guide. Be certain to note the guide's orientation on the payload section. Wrap this guide around the payload section of the upper body tube. Using a pencil, mark the outline of the two antenna shoes on the payload section. Remove this guide and save it for later reference.
5. The AeroTech Astrobee D kit may be completed in two different configurations:

FLIGHT CONFIGURATION: Cut out decal 'L' from the decal sheet. Position this decal so that it is centered over the paint separation line between the gray payload section and white airframe. Using the decal placement drawing, begin wrapping the decal around the body tube. Observe during the wrapping that the decal is aligned. (See Decal Instructions for decal application information.)

LAUNCH CONFIGURATION: Locate the self adhesive aluminum band. Note its position on the Decal Location Guide 5.87" (149mm) from the front of the upper body tube. Remove the backing tape from the band. Start wrapping the aluminum band around the body tube,

beginning at the point indicated on the decal placement drawing. Continue to wrap the band around the body until it is completely finished. (NOTE: The adhesive on the band is very strong and care should be taken to position the band properly as the adhesive can pull up the paint.) There will be a gap between the ends of band once wrapped around the body tube and this is normal.

Find the remaining piece of the plastic launch lug rail. Cut off a piece 1.31" (33.2mm) long. Wash this part in a detergent/soap bath. Rinse and let dry. Cut off 10 of the plastic fasteners from their holders. Wash these parts as before and allow to dry. Using the Fastener Location Guide, cement 5 of these fasteners to each side of the launch lug rail. When the cement is dry, paint this assembly silver.

Apply cement to the bottom of the launch lug rail/fastener assembly. Center this piece over the gap between the ends of the aluminum band and press firmly into place. Hold in position until the cement sets up.

6. Carefully cut out the self adhesive decals and apply them to the model in the positions noted on the Decal Location Guide. Make certain to line up the upper and lower body tubes for correct placement of decals.
7. Tie loops in the ends of both shock cords. Thread the 30" (76cm) parachute shroud lines through the loop in the lower body tube shock cord. Stretch out the shroud lines of the parachute so that the lines form three (3) loops on top of the other. Pass the canopy of the parachute through three (3) loops made by the shroud lines and pull tight. Repeat this procedure with the 22" (56cm) parachute and upper body assembly.
8. Using a pair of pliers, carefully crimp one end of each of the antenna tubes into an open square shape. Carefully push the crimped end of the aluminum tubes on to the fittings at the end of the antenna shoes. It may be necessary to crimp the ends more or to open them up depending on their fit. These pieces are to be removed when flying on the Astrobee D kit to prevent any damage to the antenna shoes.

OPERATION INSTRUCTIONS

1. **RECOMMENDED MOTORS:** Only use AEROTECH composite model rocket motors when flying your AEROTECH rocket. See enclosed chart for recommended motors and projected altitudes.
2. **RECOVERY SYSTEM PREPARATION:** Roll the parachute and shroud lines for the upper body assembly. Start from the canopy peak and roll this parachute and shroud lines into a tight cylinder that will easily slide into the lower body tube/fin unit. Place this parachute into the lower body tube followed by the shock cord. Roll the parachute and shroud lines for the lower body tube/fin unit. Start from the canopy peak and roll this parachute and shroud lines into a loose cylinder. Pack the lower body assembly parachute on top of the upper body parachute and shock cord previously installed in the rocket. Pack the lower body shock cord on top of this parachute. Insert the remaining shock cord length into the body tube and insert the coupler tube for the upper body assembly. Make sure that the parachutes, shroud lines and shock cords are not caught between the body tube and the shoulder of the upper body assembly. The upper body unit should slide freely. (NOTE: Because your AEROTECH rocket has the LABYRINTH™ ejection gas cooling system, no recovery wadding is required.)
3. **MOTOR PREPARATION:** The motors recommended for your AEROTECH rocket vary in physical size as well as performance. Your rocket comes with a changeable motor adaptor and spacer tubes that permit the rocket to use each of the recommended motors without permanent modification to the rocket.

Prepare your AEROTECH rocket motor according to the instructions that come with the motor. Be sure the motor hook snaps in behind the nozzle end of the motor and holds the motor securely in place. If the motor hook does not hold the motor in place, bend the end of the hook until it does.
4. **PRE-LAUNCH CHECKOUT:** Before **EVERY** flight, perform a complete pre-launch checkout of your rocket;
 - Check that all fins and launch lugs are mounted securely and not damaged.
 - Examine the body tube, nose cone and payload bay to make sure they are free of damage.
 - Check that the shock cord is securely mounted to the ejection gas baffle and nose cone (or payload bay bulkhead).
 - Check that the parachute is securely tied to the shock cord.
 - Check that the shock cord and parachute are free of any damage.
 - See that the nose cone (or payload bay), packed parachute and shock cord move freely. After awhile, an ejection charge residue may build up at the top inside surface of the body tube. Wipe this residue away with isopropyl ("rubbing") alcohol.
 - With the tail of the rocket pointed down and the motor tube empty, shake the rocket to remove any loose ejection charge debris left from a previous flight. Periodically, fluff up the cooling mesh using a bent wire inserted through the back end of the motor tube.
 - Be certain the motor to be used is a recommended AEROTECH model rocket motor and of a size appropriate for the launch area.
 - Be sure the motor hook, motor adaptor and motor tube are not damaged and hold the motor securely in place.
5. **LAUNCH PAD:** Your AEROTECH rocket must be flown from a launch pad with a 1/4"(6.4mm) diameter metal launch rod at least 36"(0.9m) long (as measured from the top of the blast deflector), such as the AEROTECH MANTIS™ model rocket launch pad.
6. **MOTOR IGNITION:** Only launch your rocket using a remotely controlled and electrically operated launch controller such as the AEROTECH® INTERLOCK™ model rocket launch controller. Keep yourself and all other people at least 30 feet (10 meters) away from the rocket during launch.
7. **LAUNCH AREA:** Launch the rocket in a cleared outdoor area free of tall trees, power lines and buildings. The side dimensions of the cleared area should be at least one half of the projected altitude. An area for a radius of at least 5 feet (1.5 meters) from the launcher should be clear of dry grass or other flammable substances. Read and follow the Model Rocket Safety Code of the National Association of Rocketry (NAR) and comply with all federal, state and local laws in all activities with model rockets. A copy of the NAR safety code is shown on the instructions that come with all AEROTECH composite model rocket motors.
8. **FLIGHT PROFILE:** When the launch button of the electrical launch controller is pressed, an electrical current causes the AEROTECH COPPERHEAD™ single lead igniter to ignite the composite propellant of the AEROTECH rocket motor. The motor quickly builds up thrust and powers your AEROTECH rocket into the air. During powered flight the rocket increases in speed and altitude. When the propellant burns out the rocket is moving at maximum velocity and a time delay material (delay grain) inside the motor burns. While the delay grain burns the rocket coasts to peak altitude at which point the delay grain ignites the ejection charge within the forward part of the motor. The ignition of the ejection charge creates a burst of hot expanding gas which is cooled by the permanent metal mesh of the LABYRINTH™ ejection gas cooling system. The cooled gas flows around the baffle, pressurizes the parachute bay and ejects the nose cone (or payload bay) and parachute. The parachute then deploys and gently returns the rocket to the ground where the rocket can be prepared for another flight.
9. **TRANSPORT AND STORAGE:** To avoid damage to your AEROTECH rocket during transport, pack it in a box surrounded by soft packing. Store your rocket at room temperature.

NOTICE: As we cannot control the storage and use of our products, once sold we cannot assume any responsibility for product storage, transportation or usage. RCS shall not be held responsible for any personal injury or property damage resulting from the handling, storage or use of our product. The buyer assumes all risks and liabilities therefrom and accepts and uses AeroTech/RCS products on these conditions.

No warranty either expressed or implied is made regarding AeroTech/RCS products, except for replacement or repair, at RCS's option, of those products which are proven to be defective in manufacture within one year from the date of original purchase. For repair or replacement under this warranty, please contact RCS. Proof of purchase will be required. Note: Your state may provide additional rights not covered by this warranty.

DECAL INSTRUCTIONS

1. Handle the decal sheet carefully to avoid damage. Do not crease the decal sheet.
2. Use a pair of sharp scissors or a hobby knife to cut out the decals.
3. Cutting out decals that will be positioned close together on the rocket as one block will make them easier to apply.
4. Make smooth cuts. Small knicks can cause a decal to tear when it is being peeled off the backing sheet.
5. Before starting to peel decals off their backings, fill a soup bowl with warm water and put one or two drops of a dishwashing detergent into the water.
6. Carefully peel a decal off its backing, dip it into the detergent solution and apply the decal to the rocket. The detergent solution prevents the adhesive on the decal from "grabbing" the rocket surface too quickly and allows accurate positioning of the decal.
7. Gently press any air bubbles out from under the decal and then dab the decal dry.
8. Apply the rest of the decals in the same manner.

ASTROBEE D MARKING AND CUTTING GUIDE

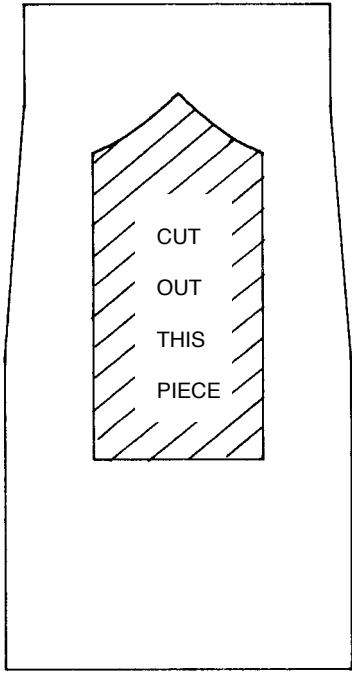

AFT END OF BODY TUBE

FASTENER LOCATION GUIDE

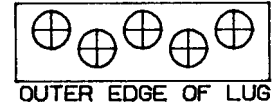

AFT LAUNCH LUG CUTTING GUIDES

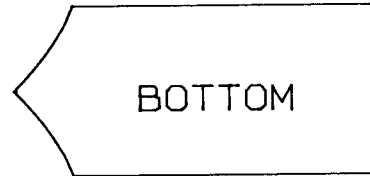
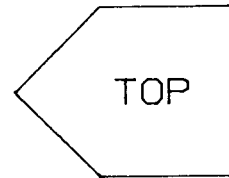

ASTROBEE D PAYLOAD SECTION
 ANTENNA AND DECAL PLACEMENT GUIDE

