

8

7

6

5

4

3

2

1

### REVISIONS

| EFFECTIVITY | REV | DESCRIPTION         | DATE        | APPROVED |
|-------------|-----|---------------------|-------------|----------|
| FUTURE      | A   | FIRST RELEASE ISSUE | 11 / 9 / 99 |          |

#### NOTES:

1. MOTOR ASSEMBLY SHOWN WITH SPECIFIED MOTOR HARDWARE & RELOAD KIT.

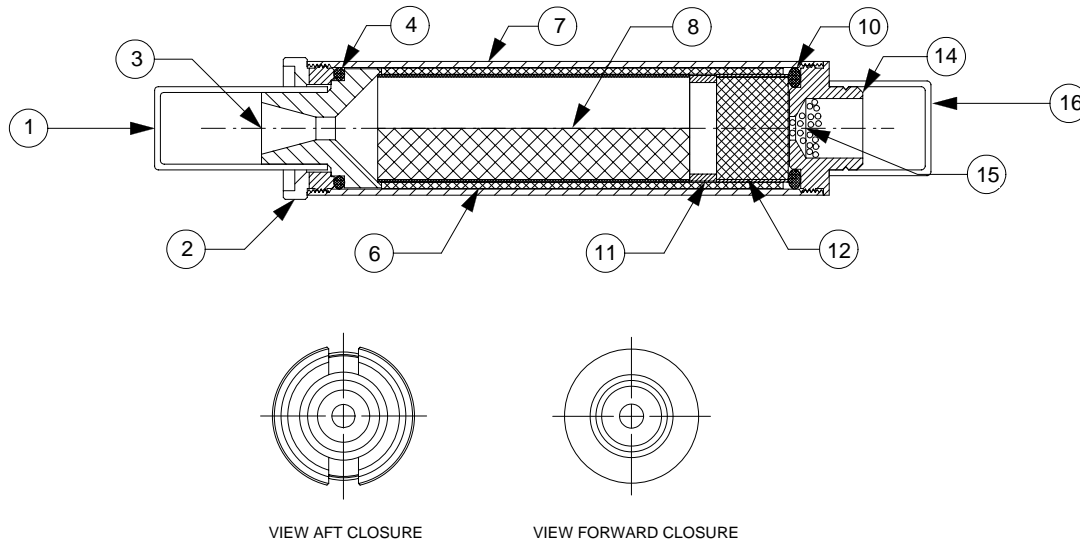

| QTY | PART NUMBER | DESCRIPTION                             | ITEM |
|-----|-------------|---|------|
| 1   | 04716       | EJECTION CHARGE CAP (7/16" I.D.)        | 16   |
| 1   | 03700       | EJECTION CHARGE (.4 GRAMS)              | 15   |
| 1   | 910043E     | FORWARD CLOSURE                         | 14   |
| NA  |             | DELAY INSULATOR                         | 13   |
| 1   | 03203       | DELAY GRAIN (.562" O.D. X .375")        | 12   |
| 1   | 03052       | DELAY SPACER (.553" O.D. X .140")       | 11   |
| 1   | 00111       | FORWARD O-RING (5/8" O.D. X 3/32") 111  | 10   |
| NA  |             | FORWARD INSULATOR                       | 9    |
| 1   | 03481-2     | PROPELLANT GRAINS (.562" O.D. X 1.625") | 8    |
| 1   | 910041B     | CASE                                    | 7    |
| 1   | 02000       | LINER (.629" O.D. X 2.093")             | 6    |
| NA  |             | AFT INSULATOR                           | 5    |
| 1   | 00014       | AFT O-RING (5/8" O.D. X 1/16") 014      | 4    |
| 1   | 01050       | NOZZLE (D21)                            | 3    |
| 1   | 910042D     | AFT CLOSURE                             | 2    |
| 1   | 04380       | NOZZLE CAP (3/8" I.D.)                  | 1    |

| SUPPLIER DATA |  | RELOAD KIT IDENTIFICATION                           |                  |
|---------------|--|---|------------------|
| AEROTECH INC. |  | 42407   | D24-7T           |
|               |  | UNLESS OTHERWISE SPECIFIED DIMENSIONS ARE IN INCHES |                  |
|               |  | .XX<br>+/- .010                                     | .XXX<br>+/- .005 |
|               |  | ANGLES<br>+/- 2 deg.                                |                  |
|               |  | MATERIAL  |                  |
|               |  | NOTED   |                  |
|               |  | FINISH  |                  |
|               |  | PART NUMBER   | DESCRIPTION      |

|                 |              |  |  |
|-----------------|--------------|--|--|
| CONTRACT NUMBER |              | 2113 W. 850 N. Street<br>Cedar City, Utah 84720<br>(435) 865-7100 (Ph)<br>(435) 865-7120 (Fax) |  |
| PREP            | B. ROSENFELD | 7 / 99   | <b>RMS-18/20 MOTOR WITH D24-7T<br/>         RELOAD KIT</b> |
| CHKR            |              |  |  |
| APVD            |              |  |  |
| SIZE            |              | NUMBER   |  |
| A               |              | ASSY DWG   |  |
| SCALE 1 / 1     |              | SHEET 1 OF 1   |  |

8

7

6

5

4

3

2

1