

8

7

6

5

4

3

2

1

REVISIONS

EFFECTIVITY	REV	DESCRIPTION	DATE	APPROVED
FUTURE	A	FIRST RELEASE ISSUE	11 / 9 / 99	

NOTES:

1. MOTOR ASSEMBLY SHOWN WITH SPECIFIED MOTOR HARDWARE & RELOAD KIT.

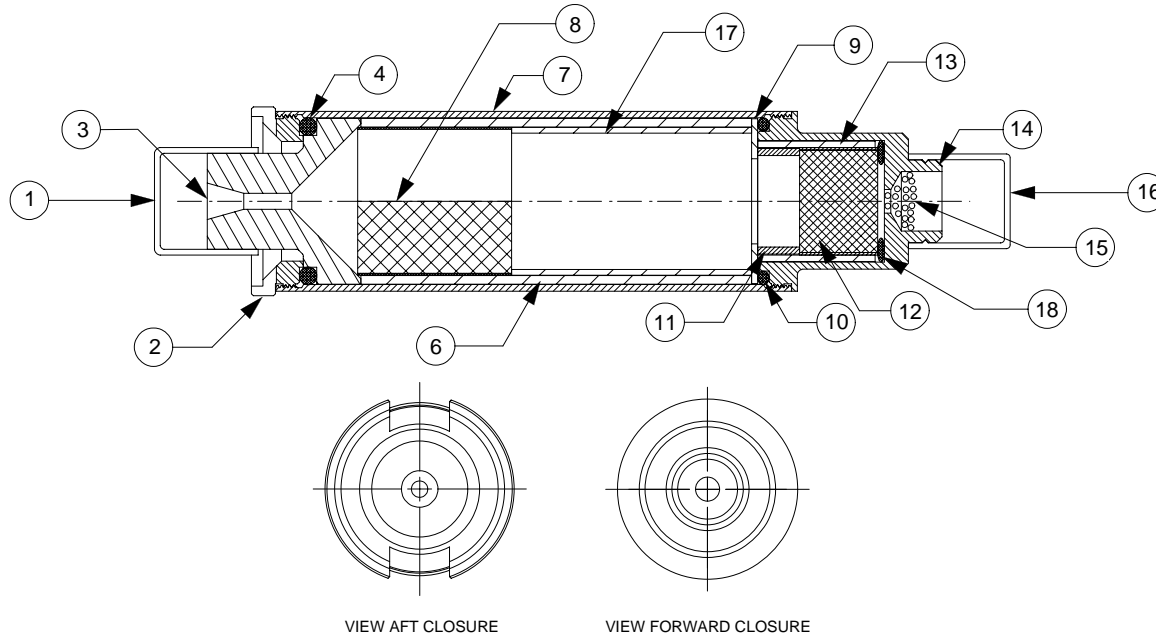

1	00111	DELAY O-RING (5/8" O.D. X 3/32") 111	18
1	03100	GRAIN SPACER (.77" O.D. X 1.25")	17
1	04716	EJECTION CHARGE CAP (7/16" I.D.)	16
1	03700	EJECTION CHARGE (.5 GRAMS)	15
1	91243	FORWARD CLOSURE	14
1	03070	DELAY INSULATOR (.629" O.D. X .613)	13
1	03206	DELAY GRAIN (.562" O.D. X .407")	12
1	03054	DELAY SPACER (.553" O.D. X .219")	11
1	00018	FORWARD O-RING (7/8" O.D. X 1/16") 018	10
1	05400	FORWARD INSULATOR (.860" O.D. X .032)	9
1	03493	PROPELLANT GRAINS (.772" O.D. X .802")	8
1	910793A	CASE	7
1	02010	LINER (.862" O.D. X 2.03")	6
NA		AFT INSULATOR	5
1	00115	AFT O-RING (7/8" O.D. X 3/32") 115	4
1	01250	NOZZLE (E6/E15)	3
1	910791C	AFT CLOSURE	2
1	04120	NOZZLE CAP (1/2" I.D.)	1

SUPPLIER DATA		RELOAD KIT IDENTIFICATION		UNLESS OTHERWISE SPECIFIED DIMENSIONS ARE IN INCHES		
AEROTECH INC.		40904	D9-4W	.XX +/- .010	.XXX +/- .005	ANGLES +/- 2 deg.
				MATERIAL		
				NOTED		
				FINISH		
		PART NUMBER	DESCRIPTION			

CONTRACT NUMBER		LIST OF MATERIAL	
		<p>AEROTECH CONSUMER AEROSPACE</p> <p>2113 W. 850 N. Street Cedar City, Utah 84720 (435) 865-7100 (Ph) (435) 865-7120 (Fax)</p>	
PREP	B. ROSENFELD	7 / 99	RMS-24/40 MOTOR WITH D9-4W RELOAD KIT
CHKR			ASSY DWG
APVD		SIZE A	NUMBER
APVD		SCALE 1 / 1	SHEET 1 OF 1

8

7

6

5

4

3

2

1