

8

7

6

5

4

3

2

1

REVISIONS

| EFFECTIVITY | REV | DESCRIPTION         | DATE        | APPROVED |
|-------------|-----|---------------------|-------------|----------|
| FUTURE      | A   | FIRST RELEASE ISSUE | 11 / 9 / 99 |          |

NOTES:

1. MOTOR ASSEMBLY SHOWN WITH SPECIFIED MOTOR HARDWARE & RELOAD KIT.

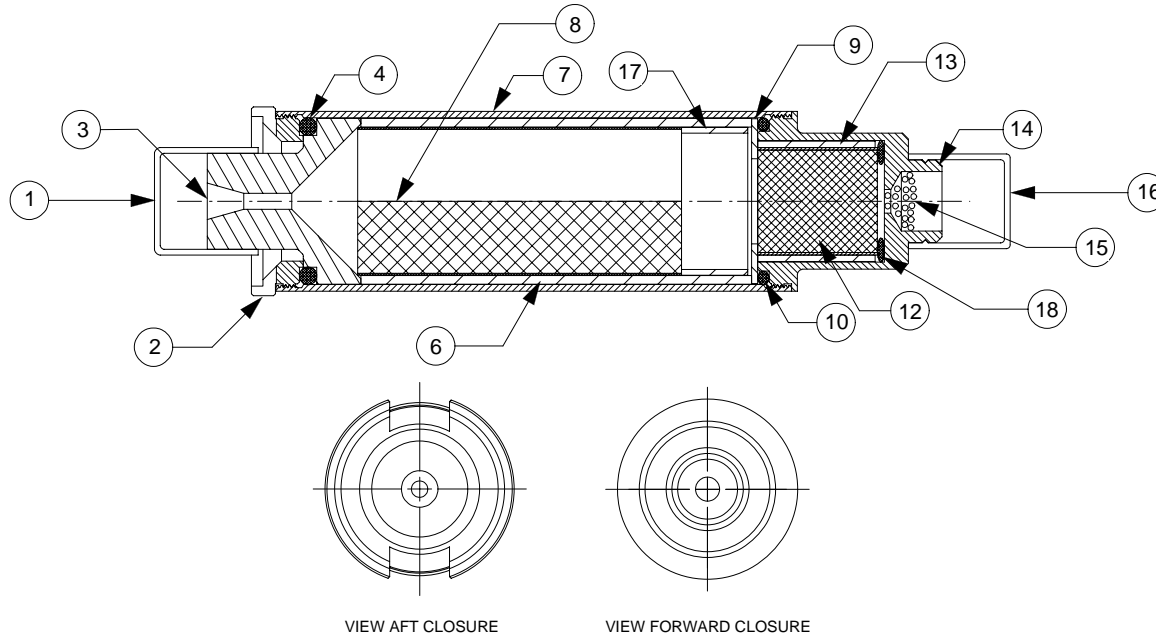

| 1   | 00111       | DELAY O-RING (5/8" O.D. X 3/32") 111    | 18   |
|-----|-------------|---|------|
| 1   | 03101       | GRAIN SPACER (.77" O.D. X .344")        | 17   |
| 1   | 04716       | EJECTION CHARGE CAP (7/16" I.D.)        | 16   |
| 1   | 03700       | EJECTION CHARGE (.5 GRAMS)              | 15   |
| 1   | 91243       | FORWARD CLOSURE                         | 14   |
| 1   | 03070       | DELAY INSULATOR (.629" O.D. X .613)     | 13   |
| 1   | 03213       | DELAY GRAIN (.562" O.D. X .625")        | 12   |
| NA  |             | DELAY SPACER                            | 11   |
| 1   | 00018       | FORWARD O-RING (7/8" O.D. X 1/16") 018  | 10   |
| 1   | 05400       | FORWARD INSULATOR (.860" O.D. X .032)   | 9    |
| 1   | 03502-2     | PROPELLANT GRAINS (.772" O.D. X 1.688") | 8    |
| 1   | 910793A     | CASE                                    | 7    |
| 1   | 02010       | LINER (.862" O.D. X 2.03")              | 6    |
| NA  |             | AFT INSULATOR                           | 5    |
| 1   | 00115       | AFT O-RING (7/8" O.D. X 3/32") 115      | 4    |
| 1   | 01250       | NOZZLE (E6/E15)                         | 3    |
| 1   | 910791C     | AFT CLOSURE                             | 2    |
| 1   | 04120       | NOZZLE CAP (1/2" I.D.)                  | 1    |
| QTY | PART NUMBER | DESCRIPTION                             | ITEM |

| SUPPLIER DATA |             | RELOAD KIT IDENTIFICATION |        |
|---------------|-------------|---------------------------|--------|
| AEROTECH INC. |             | 51103                     | E11-3J |
|               |             |                           |        |
|               |             |                           |        |
|               |             |                           |        |
|               |             |                           |        |
|               |             |                           |        |
|               |             |                           |        |
|               |             |                           |        |
|               |             |                           |        |
| PART NUMBER   | DESCRIPTION |                           |        |

UNLESS OTHERWISE SPECIFIED DIMENSIONS ARE IN INCHES

.XX +/- .010 .XXX +/- .005 ANGLES +/- 2 deg.

MATERIAL

NOTED

FINISH

LIST OF MATERIAL

CONTRACT NUMBER

PREP B. ROSENFELD 7 / 99

CHKR

APVD

APVD

SCALE 1 / 1

SHEET 1 OF 1

2113 W. 850 N. Street Cedar City, Utah 84720 (435) 865-7100 (Ph) (435) 865-7120 (Fax)

**AEROTECH**  
CONSUMER AEROSPACE

**RMS-24/40 MOTOR WITH E11-3J RELOAD KIT**

SIZE **A** NUMBER **ASSY DWG**

8

7

6

5

4

3

2

1