

8

7

6

5

4

3

2

1

REVISIONS

EFFECTIVITY	REV	DESCRIPTION	DATE	APPROVED
FUTURE	A	FIRST RELEASE ISSUE	11/11/99	
FUTURE	B	RMS-PLUS™ DELAY SYSTEM (SEE E.O.)	3/2/00	

NOTES:

1. MOTOR ASSEMBLY SHOWN WITH SPECIFIED MOTOR HARDWARE & RELOAD KIT.

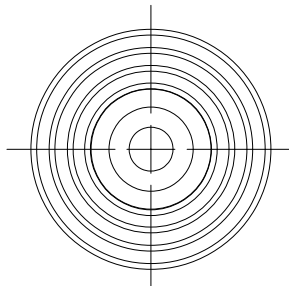
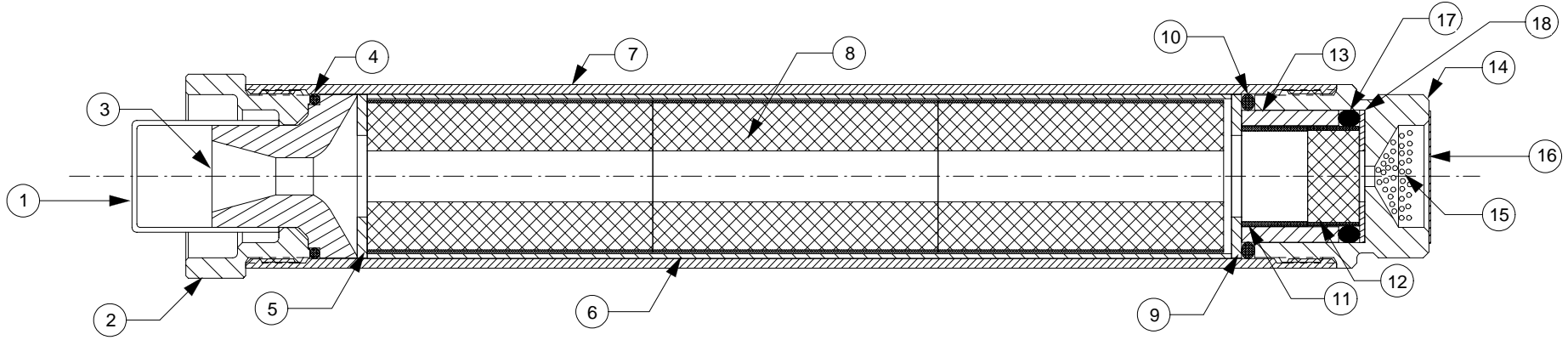

VIEW AFT CLOSURE

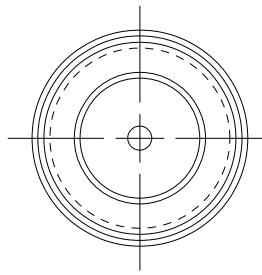

VIEW FORWARD CLOSURE

1	03350	FWD DELAY SPACER (13/16" O.D. X .031")	18
1	00001	DELAY O-RING (15MM I.D. X 3MM THICK)	17
1	05602	EJECTION CHARGE CAP (13/16")	16
1	03700	EJECTION CHARGE (FILLS WELL 3/4 FULL)	15
1	29FCC	FORWARD CLOSURE	14
1	03300	DELAY INSULATOR (.807" O.D. X .594")	13
1	03358	DELAY GRAIN (.610" O.D. X .314")	12
1	03330	AFT DELAY SPACER (.615" O.D. X .405")	11
1	00117	FORWARD O-RING (1" O.D. X 3/32")	10
1	05402	FORWARD INSULATOR(1"O.D.X.5" I.D.X1/16")	9
3	03541-2	PROPELLANT GRAINS (.933" O.D. X 1.750")	8
1	2918C	CASE	7
1	02035	LINER (1.00" O.D. X 5.298")	6
1	05402	AFT INSULATOR (1" O.D. X .5" I.D. X 1/16")	5
1	00020	AFT O-RING (1" O.D. X 1/16")	4
1	01500-5	NOZZLE (F60/G80) DRILLED .228"	3
1	29ACC	AFT CLOSURE	2
1	04580	NOZZLE CAP (5/8" I.D.)	1

QTY	PART NUMBER	DESCRIPTION	ITEM
LIST OF MATERIAL			
CONTRACT NUMBER		AEROTECH CONSUMER AEROSPACE 2113 W. 850 N. Street Cedar City, Utah 84720 (435) 865-7100 (Ph) (435) 865-7120 (Fax)	
PREP	B. ROSENFELD	8 / 99	HP-29/180 MOTOR WITH H238T-S RMS-PLUS™ RELOAD KIT
CHKR			
APVD			
APVD			
SIZE		A	
NUMBER		ASSY DWG	
SCALE		1 / 1	
			SHEET 1 OF 1

SUPPLIER DATA		RELOAD KIT IDENTIFICATION		UNLESS OTHERWISE SPECIFIED DIMENSIONS ARE IN INCHES		
AEROTECH INC.		08238S	H238T-S RMS-PLUS	.XX	.XXX	ANGLES
				+/- .010	+/- .005	+/- 2 deg.
				MATERIAL		
				NOTED		
				FINISH		
				PART NUMBER		
				DESCRIPTION		

8

7

6

5

4

3

2

1