

8

7

6

5

4

3

2

1

### REVISIONS

EFFECTIVITY	REV	DESCRIPTION	DATE	APPROVED
FUTURE	A	FIRST RELEASE ISSUE	11 / 11 / 99	

#### NOTES:

1. MOTOR ASSEMBLY SHOWN WITH SPECIFIED MOTOR HARDWARE & RELOAD KIT.

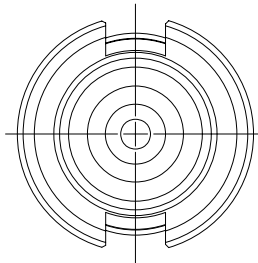
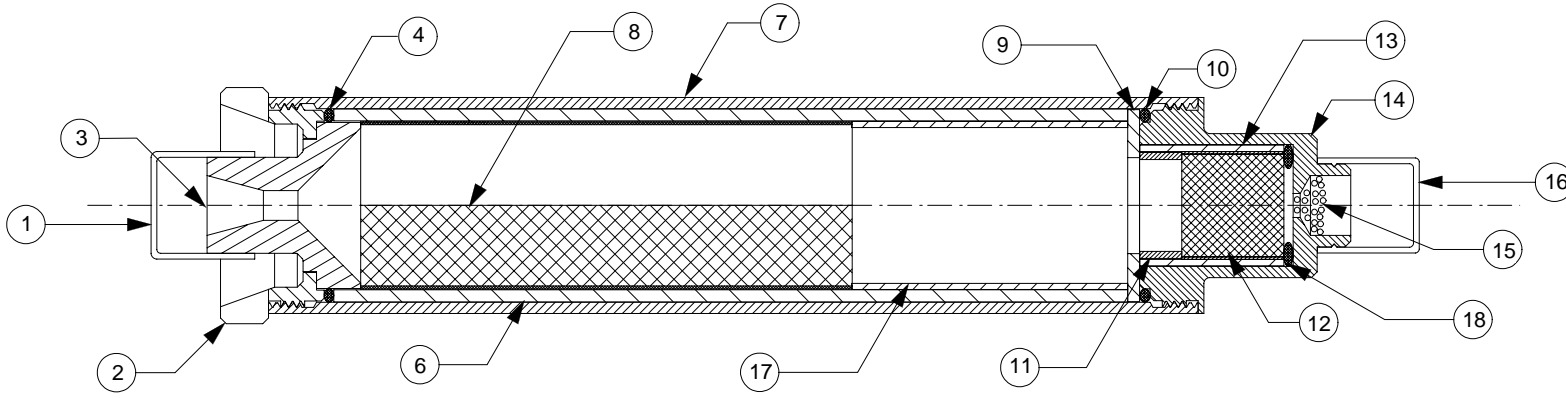

VIEW AFT CLOSURE

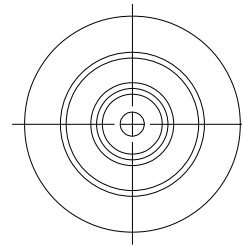

VIEW FORWARD CLOSURE

1	00111	DELAY O-RING (5/8" O.D. X 3/32") 111	18
1	03106	GRAIN SPACER (.862" O.D. X 1.438")	17
1	04716	EJECTION CHARGE CAP (7/16" I.D.)	16
1	03700	EJECTION CHARGE (.7 GRAMS)	15
1	91292	FORWARD CLOSURE	14
1	03072	DELAY INSULATOR (.629" O.D. X .75")	13
1	03211	DELAY GRAIN (.562" O.D. X .531")	12
1	03054	DELAY SPACER (.553" O.D. X .219")	11
1	00020	FORWARD O-RING (1" O.D. X 1/16") 020	10
1	05402	FORWARD INSULATOR (1" O.D.X.5" I.D.X1/16")	9
1	03528-2	PROPELLANT GRAINS (.872" O.D. X 2.562")	8
1	910813A	CASE	7
1	02020	LINER (1.005" O.D. X 4.14")	6
NA		AFT INSULATOR	5
1	00020	AFT O-RING (1" O.D. X 1/16") 020	4
1	01350-1	NOZZLE (E30/E50) DRILLED .156"	3
1	910811C	AFT CLOSURE	2
1	04120	NOZZLE CAP (1/2" I.D.)	1

QTY	PART NUMBER	DESCRIPTION	ITEM
LIST OF MATERIAL			
CONTRACT NUMBER		<b>AEROTECH</b> CONSUMER AEROSPACE 2113 W. 850 N. Street Cedar City, Utah 84720 (435) 865-7100 (Ph) (435) 865-7120 (Fax)	
PREP	B. ROSENFELD		
CHKR			
APVD		SIZE <b>A</b> NUMBER	
APVD		<b>ASSY DWG</b>	
SCALE 1 / 1		SHEET 1 OF 1	

SUPPLIER DATA		RELOAD KIT IDENTIFICATION		UNLESS OTHERWISE SPECIFIED DIMENSIONS ARE IN INCHES		
AEROTECH INC.		65211	F52-11T	.XX	.XXX	ANGLES
				+/- .010	+/- .005	+/- 2 deg.
				MATERIAL		
				NOTED		
				FINISH		
		PART NUMBER	DESCRIPTION			

8

7

6

5

4

3

2

1