

8

7

6

5

4

3

2

1

REVISIONS

EFFECTIVITY	REV	DESCRIPTION	DATE	APPROVED
FUTURE	A	FIRST RELEASE ISSUE	3 / 20 / 08	
FUTURE	B	CHANGED DELAY LENGTH, SPACER LENGTH & THROAT DIAMETER	6 / 2 / 08	

NOTES:

- MOTOR ASSEMBLY SHOWN WITH SPECIFIED MOTOR HARDWARE & RELOAD KIT.

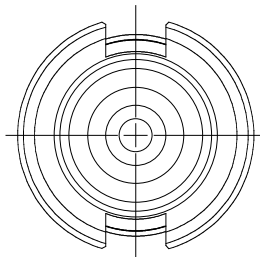
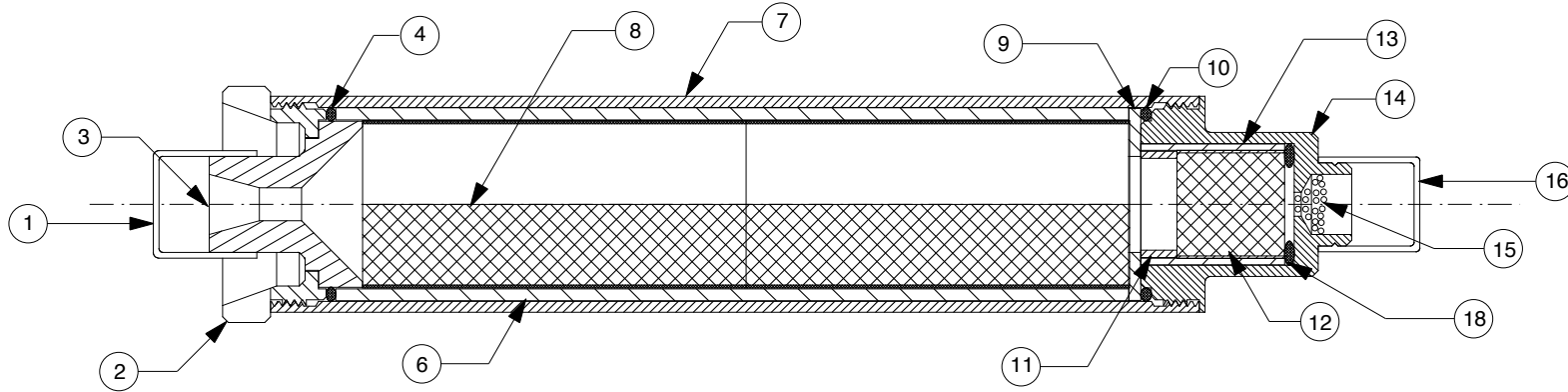

VIEW AFT CLOSURE

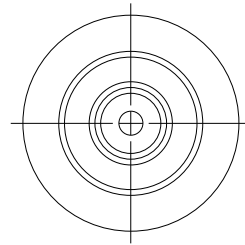

VIEW FORWARD CLOSURE

1	00111	DELAY O-RING (5/8" O.D. X 3/32")	111	18
NA		GRAIN SPACER		17
1	04716	EJECTION CHARGE CAP (7/16" I.D.)		16
1	03700	EJECTION CHARGE (.7 GRAMS)		15
1	91292	FORWARD CLOSURE		14
1	03072	DELAY INSULATOR (.629" O.D. X .75")		13
1	03212	DELAY GRAIN (.562" O.D. X .562")		12
1	03053	DELAY SPACER (.553" O.D. X .188") MAGENTA		11
1	00020	FORWARD O-RING (1" O.D. X 1/16")	020	10
1	05402	FORWARD INSULATOR (1" O.D. X 5/16" I.D. X 1/16")		9
2	03G011	PROPELLANT GRAINS (.872" O.D. X 2.000")		8
1	910813A	CASE		7
1	02020	LINER (1.005" O.D. X 4.14")		6
NA		AFT INSULATOR		5
1	00020	AFT O-RING (1" O.D. X 1/16")	020	4
1	01350-4	NOZZLE (E30/E50) DRILLED 0.172"		3
1	910811C	AFT CLOSURE		2
1	04120	NOZZLE CAP (1/2" I.D.)		1

QTY	PART NUMBER	DESCRIPTION	ITEM
LIST OF MATERIAL			
CONTRACT NUMBER		 2113 W. 850 N. Street Cedar City, Utah 84720 (435) 865-7100 (Ph) (435) 865-7120 (Fax)	
PREP	G. ROSENFELD		
CHKR			
APVD		SIZE	NUMBER
APVD		A	ASSY DWG
SCALE 1 / 1		SHEET 1 OF 1	

SUPPLIER DATA

AEROTECH DIV., RCS RMC INC.

RELOAD KIT IDENTIFICATION

77510

G76-10G

UNLESS OTHERWISE SPECIFIED DIMENSIONS ARE IN INCHES

.XX +/- .010	.XXX +/- .005	ANGLES +/- 2 deg.
-----------------	------------------	----------------------

MATERIAL

NOTED

FINISH

PART NUMBER

DESCRIPTION

8

7

6

5

4

3

2

1