

8

7

6

5

4

3

2

1

REVISIONS

EFFECTIVITY	REV	DESCRIPTION	DATE	APPROVED
FUTURE	A	REV FWD INSULATOR DISC PART NUMBER	6 / 21 / 00	

NOTES:

- 1. MOTOR ASSEMBLY SHOWN WITH SPECIFIED MOTOR HARDWARE & RELOAD KIT.

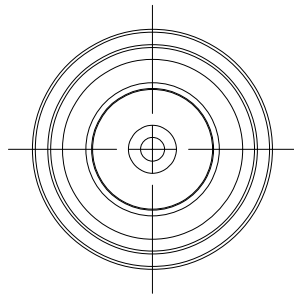

VIEW AFT CLOSURE

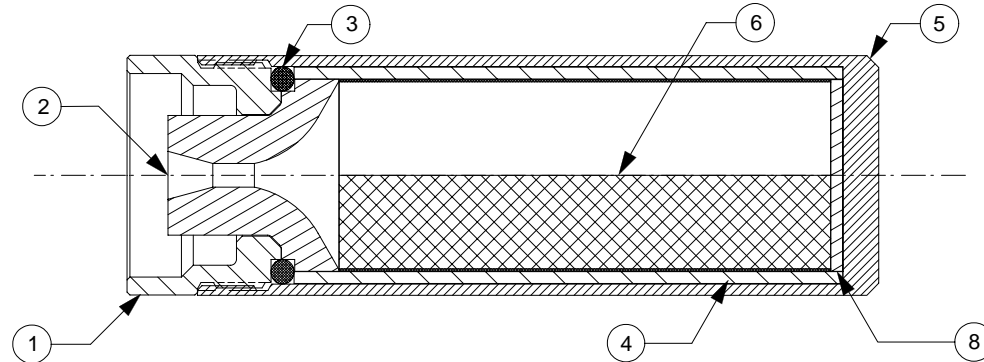

1	05403	FORWARD INSULATOR (1.00" O.D. X .062")	8
NA		GRAIN SPACER TUBE	7
1	03567	PROPELLANT GRAINS (1.00 O.D." X 2.562")	6
1	011496-01	CASE	5
1	02050	LINER (1.13" O.D. X 2.860")	4
1	00212	AFT O-RING (1 1/8" X 1/8") 212	3
1	01400-2	NOZZLE (F10/F30) DRILLED .125"	2
1	902604A	AFT CLOSURE	1
QTY	PART NUMBER	DESCRIPTION	ITEM

SUPPLIER DATA		RELOAD KIT IDENTIFICATION	
AEROTECH INC.		91616	F16-RCJ
UNLESS OTHERWISE SPECIFIED DIMENSIONS ARE IN INCHES			
.XX +/- .010		.XXX +/- .005	ANGLES +/- 2 deg.
MATERIAL			
NOTED			
FINISH			
PART NUMBER	DESCRIPTION		

LIST OF MATERIAL			
CONTRACT NUMBER			
PREP B. ROSENFELD 8 / 99		2113 W. 850 N. Street Cedar City, Utah 84720 (435) 865-7100 (Ph) (435) 865-7120 (Fax)	
CHKR		RMS-RC 32/60 MOTOR WITH F16-RCJ RELOAD KIT	
APVD	SIZE	NUMBER	
APVD	A	ASSY DWG	
SCALE 1 / 1		SHEET 1 OF 1	

8

7

6

5

4

3

2

1