

8

7

6

5

4

3

2

1

REVISIONS

EFFECTIVITY	REV	DESCRIPTION	DATE	APPROVED
FUTURE	A	FIRST RELEASE ISSUE	5 / 02 / 06	

NOTES:

1. MOTOR ASSEMBLY SHOWN WITH SPECIFIED MOTOR HARDWARE & RELOAD KIT.

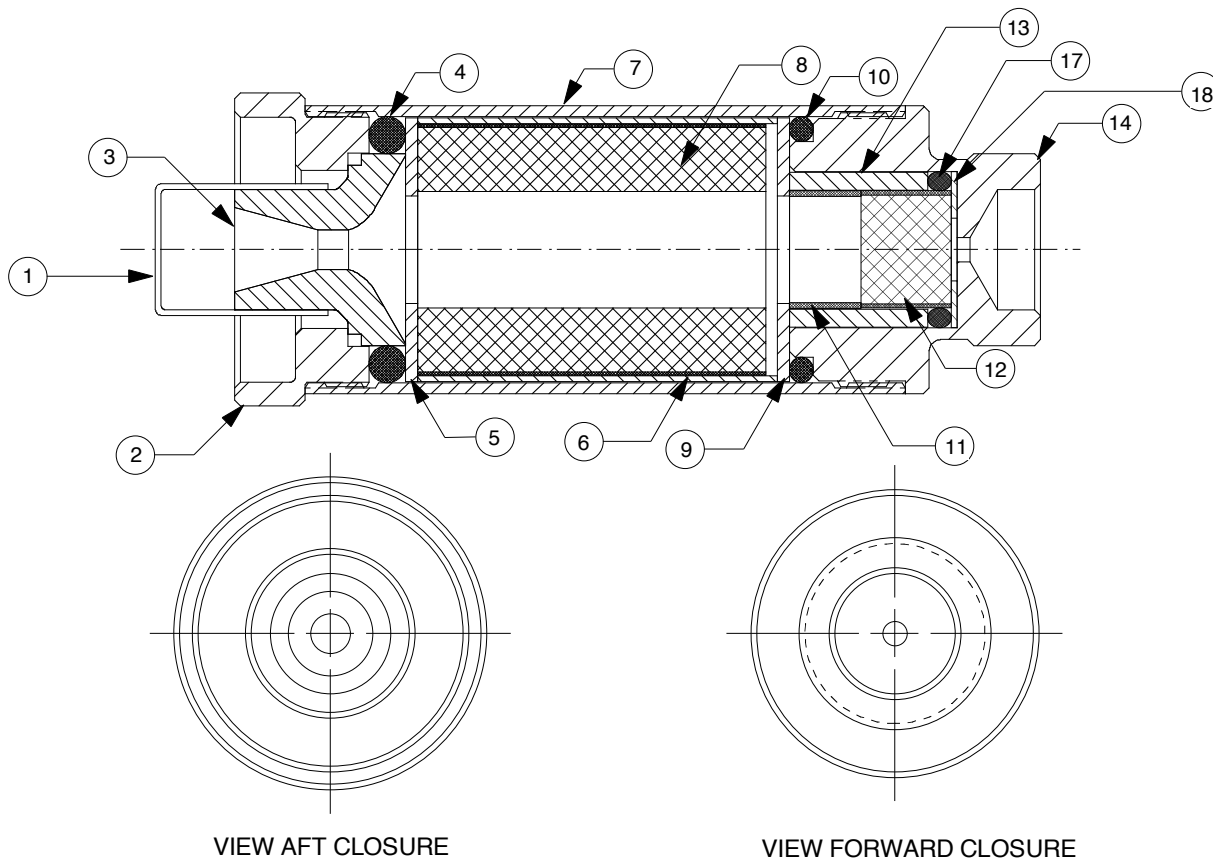

1	03350	FWD DELAY SPACER (13/16" O.D. X .031")	18
1	00001	DELAY O-RING (15MM I.D. X 3MM THICK)	17
			16
			15
1	38FCC	FORWARD CLOSURE	14
1	03302	DELAY INSULATOR (.807" O.D. X .719")	13
1	03363	DELAY GRAIN (.61" O.D. X .469")	12
1	03329	AFT DELAY SPACER (.615" O.D. X .375")	11
1	00216	FORWARD O-RING (1 3/8" O.D. X 1/8") 216	10
1	05404	FWD INSULATOR(1.375"O.D.X.562" I.D.X1/16")	9
1	03581-6	PROPELLANT (1.308" O.D. X 1.815")	8
1	3812C	CASE	7
1	02052	LINER (1.372" O.D. X 1.875")	6
1	05404	AFT INSULATOR(1.375"O.D.X.562" I.D.X1/16")	5
1	00318	AFT O-RING (1.375" O.D. X 3/16") 318	4
1	01500-2	NOZZLE (F60/G80) DRILLED .206"	3
1	38AC2	AFT CLOSURE L2	2
1	04580	NOZZLE CAP (5/8" I.D.)	1
QTY	PART NUMBER	DESCRIPTION	ITEM

LIST OF MATERIAL

CONTRACT NUMBER

RCS ROCKET MOTOR COMPONENTS, INC. 2113 W. 850 N. Street Cedar City, Utah 84720 (435) 867-9998 (Ph) (443) 222-0203 (Fax)

PREP	G. ROSENFELD	5 / 06	HP 38/120 MOTOR WITH G339N-P RMS-PLUS™ RELOAD KIT
CHKR			
APVD		SIZE	NUMBER
APVD		A	ASSY DWG
SCALE 1 / 1			SHEET 1 OF 1

SUPPLIER DATA		RELOAD KIT IDENTIFICATION	
AEROTECH DIV. RCS RMC INC.	07339P	G339N-P	
PART NUMBER	DESCRIPTION		

UNLESS OTHERWISE SPECIFIED DIMENSIONS ARE IN INCHES

.XX +/- .010	.XXX +/- .005	ANGLES +/- 2 deg.
MATERIAL		
NOTED		
FINISH		

8

7

6

5

4

3

2

1