

8

7

6

5

4

3

2

1

REVISIONS

EFFECTIVITY	REV	DESCRIPTION	DATE	APPROVED
FUTURE	A	FIRST RELEASE ISSUE	11 / 12 / 99	
FUTURE	B	RMS-PLUS™ DELAY SYSTEM (SEE E.O.)	12 / 9 / 99	

NOTES:

1. MOTOR ASSEMBLY SHOWN WITH SPECIFIED MOTOR HARDWARE & RELOAD KIT.

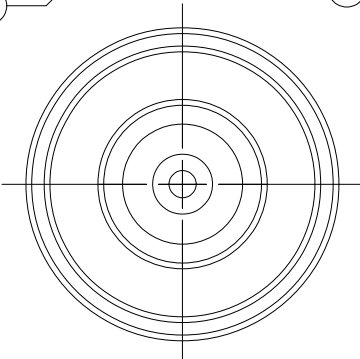
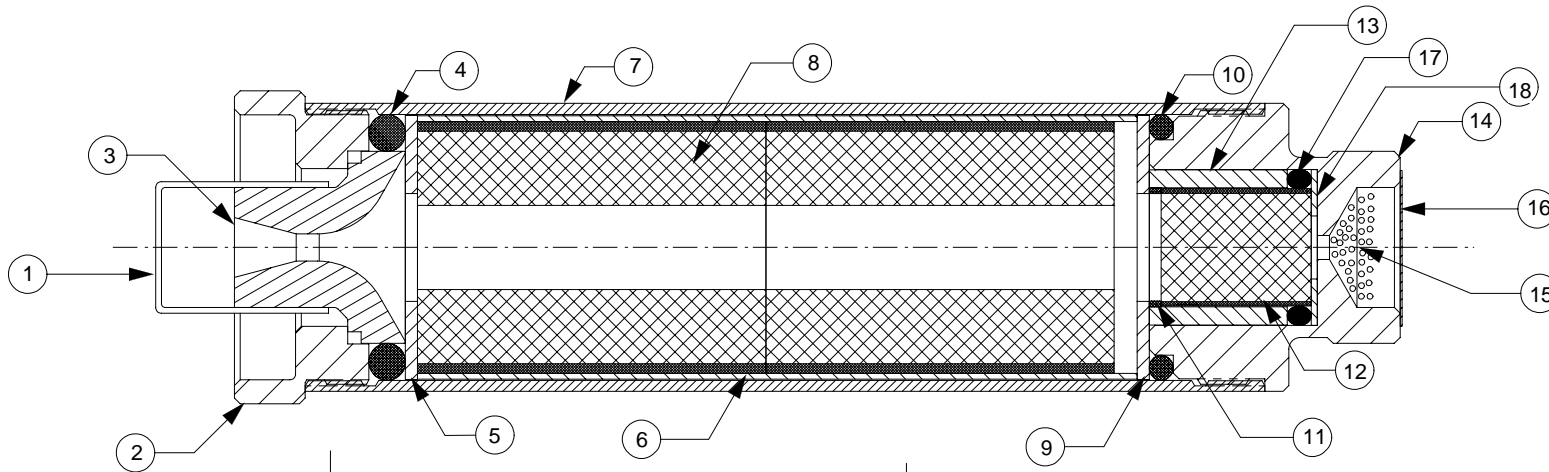

VIEW AFT CLOSURE

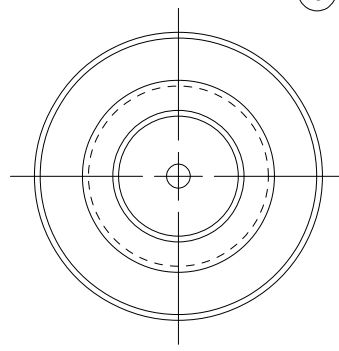

VIEW FORWARD CLOSURE

1	03350	FWD DELAY SPACER (13/16" O.D. X .031")	18
1	00001	DELAY O-RING (15MM I.D. X 3MM THICK)	17
1	05602	EJECTION CHARGE CAP	16
1	03700	EJECTION CHARGE (FILLS WELL 3/4 FULL)	15
1	38FCC	FORWARD CLOSURE	14
1	03302	DELAY INSULATOR (.807" O.D. X .719")	13
1	03384	DELAY GRAIN (.61" O.D. X .781)	12
1	03305	AFT DELAY SPACER (.615" O.D. X .063")	11
1	00216	FORWARD O-RING (1 3/8" O.D. X 1/8") 216	10
1	05404	FWD INSULATOR(1.375"O.D.X.562" I.D.X1/16")	9
2	03581-4	PROPELLANT (1.308" O.D. X 1.815") THICK	8
1	3824C	CASE	7
1	02055	LINER (1.372" O.D. X 3.750")	6
1	05404	AFT INSULATOR(1.375"O.D.X.562" I.D.X1/16")	5
1	00318	AFT O-RING (1.375" O.D. X 3/16") 318	4
1	01450	NOZZLE (G45/F60) UNDRILLED	3
1	38AC2	AFT CLOSURE L2	2
1	04580	NOZZLE CAP (5/8" I.D.)	1

SUPPLIER DATA		RELOAD KIT IDENTIFICATION		UNLESS OTHERWISE SPECIFIED DIMENSIONS ARE IN INCHES		
AEROTECH INC.		08073M	H73J-M	.XX +/- .010	.XXX +/- .005	ANGLES +/- 2 deg.
				MATERIAL		
				NOTED		
				FINISH		
		PART NUMBER	DESCRIPTION			

QTY		PART NUMBER	DESCRIPTION	ITEM
LIST OF MATERIAL				
CONTRACT NUMBER		 2113 W. 850 N. Street Cedar City, Utah 84720 (435) 865-7100 (Ph) (435) 865-7120 (Fax)		
PREP	B. ROSENFELD			
CHKR			HP 38/240 MOTOR WITH H73J-M RMS PLUS™ RELOAD KIT	
APVD				
APVD				
SIZE		A	NUMBER	
			ASSY DWG	
SCALE		1 / 1	SHEET 1 OF 1	

8

7

6

5

4

3

2

1