

8

7

6

5

4

3

2

1

REVISIONS

EFFECTIVITY	REV	DESCRIPTION	DATE	APPROVED
FUTURE	A	FIRST RELEASE ISSUE (REDLINE PROPELLANT)	05 / 29 / 01	
FUTURE	B	PER E.O. "B", NEW H/P NOZZLE #01670-2	02 / 11 / 02	
FUTURE	C	PER E.O. "C", NEW SEAL DISK & O-RING, REMOVE LINER O-RING	03 / 26 / 07	

NOTES:

- MOTOR ASSEMBLY SHOWN WITH SPECIFIED MOTOR HARDWARE & RELOAD KIT.

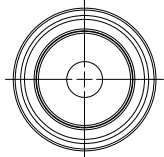
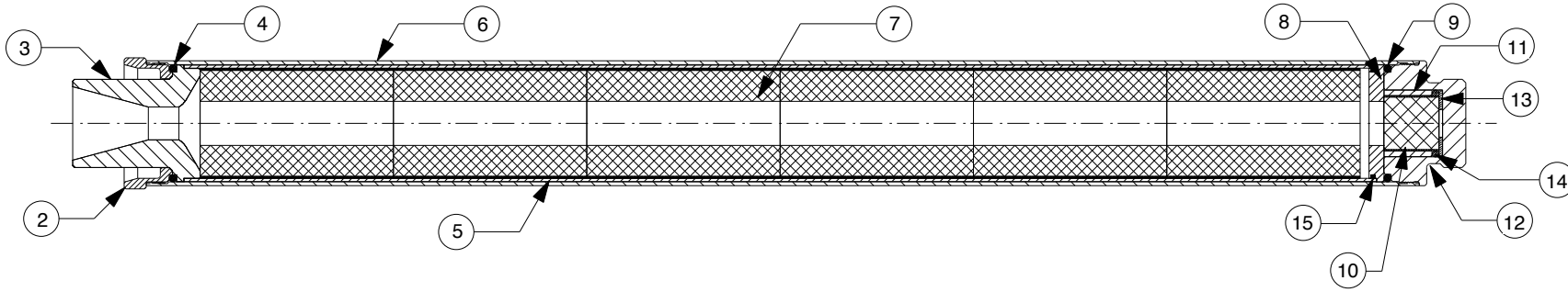

VIEW AFT CLOSURE

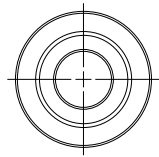

VIEW FORWARD CLOSURE

1	00031	FWD SEAL DISK O-RING (1-7/8" O.D. X 1/16") 031	15
1	00002	DELAY O-RING (1.17" O.D. X .123")	14
1	03355	FWD DELAY SPACER (1-1/8" O.D. X .062")	13
1	54FCP	FORWARD CLOSURE (PLUGGED)	12
1	03356	SMOKE CHG INSULATOR (1.13" O.D. X .815")	11
1	03924	SMOKE CHARGE (.933" O.D. X .938")	10
1	00224	FORWARD O-RING (2" O.D. X 1/8") 224	9
1	54FSD	FORWARD SEAL DISK- 54MM RMS	8
6	03602-3	PROPELLANT GRAINS (1.87" O.D. X 3.285")	7
1	5425C	CASE	6
1	03000-6	PHENOLIC LINER (1.99" O.D. X 20.270")	5
1	00224	AFT O-RING (2" O.D. X 1/8") 224	4
1	01670-2	NOZZLE, HIGH POWER (DRILLED .562")	3
1	54ACC	AFT CLOSURE	2
		NOZZLE CAP	1

SUPPLIER DATA		RELOAD KIT IDENTIFICATION		UNLESS OTHERWISE SPECIFIED DIMENSIONS ARE IN INCHES		
AEROTECH/RCS RMC INC.		111275P	K1275R-P	.XX +/- .010	.XXX +/- .005	ANGLES +/- 2 deg.
				MATERIAL		
				NOTED		
				FINISH		
		PART NUMBER	DESCRIPTION			

QTY	PART NUMBER	DESCRIPTION	ITEM
LIST OF MATERIAL			
CONTRACT NUMBER			
 2113 W. 850 N. Street Cedar City, Utah 84720 (435) 865-7100 (Ph) (435) 865-7120 (Fax)			
PREP	B. ROSENFELD	5 / 01	HP 54/2560 MOTOR WITH K1275R-P RMS-PLUS™ RELOAD KIT
CHKR			
APVD		SIZE	NUMBER
APVD		A	ASSY DWG
SCALE 1 / 3			SHEET 1 OF 1

8

7

6

5

4

3

2

1